



# SHOP PRESS ASSEMBLY INSTRUCTIONS

---

5212 - 12 Ton Manual Shop Press

5220 - 20 Ton Manual Shop Press

5220AH - 20 Ton Manual Shop Press with Pneumatic/ Hydraulic Power Unit

## PRESS SPECIFICATIONS

Sunex Part No.	A	B	C	D	E	F	G
5212	61.5"	20"	26"	8.75"	5"	.75"	Y(2)
5220	64.5"	24.5"	26"	11.25"	5.125"	1"	Y(2)
5220AH	64.5"	24.5"	26"	11.25"	5.125"	1"	Y(2)

A - Total Height

B - Inside Width

C - Press Feet Length

D - Bed Width

E - Stroke (ram travel distance from fully retracted position to fully extended position)

F - Pin Diameter

G - Press Plates Included

# SAFETY INFORMATION



THIS OPERATING MANUAL CONTAINS IMPORTANT SAFETY INFORMATION. READ CAREFULLY AND UNDERSTAND ALL INFORMATION BEFORE OPERATING THIS TOOL. SAVE THIS MANUAL FOR FUTURE USE.

## ⚠ WARNING

This symbol alerts you to the possibility of serious injury or death if instructions are not followed.

## ⚠ CAUTION

This symbol alerts you to the possibility of damage to or destruction of equipment if instructions are not followed.

## ⚠ WARNING

Failure to heed these warnings may result in loss of load, damage to the press and/or failure resulting in property damage, personal or fatal injury. This operating manual contains important details concern-

ing the safe operation of this tool. The user must read and understand these details before any use of the tool. This manual must be retained for future reference.

- Read, study, and understand all instruction manuals packed with this press before operating.
- Always wear safety goggles.
- Parts being pressed may splinter, shatter, or be ejected from the press at a dangerous rate of speed. Because of the variety of press applications, it is your responsibility to always use adequate guards and wear eye protection and heavy protective clothing when operating the press.
- Visual inspection should be made before each use of the press, checking for signs of cracked welds, bent bed pins, loose or missing bolts, leaks, or any other structural damage.
- Do not go near leaks. High pressure oil can puncture skin and cause serious injury, gangrene, or death. If injured, seek emergency medical help. Immediate surgery is required to remove oil.
- Keep hands and fingers out of the press and away from parts that may shift and pinch. Do not stand in front of work area when load is applied.
- Always use an accurate pressure gauge to measure pressing force.
- Do not exceed the rated capacity of this press.
- Never tamper with hydraulic system pressure settings.
- Do not substitute bolts, pins or any part of the components. Use only genuine factory replacement parts.
- Always center load on ram plunger. Offset loads can damage ram and may cause load to eject at a dangerous rate of speed.
- Remove all loads from press bed before attempting to adjust bed height. Beware of possibility of falling bed.
- Press only on loads supported by press bed and included press plates. Do not support loads on floor or press frame.
- When using any accessories such as arbor plates, be certain they are centered on press bed and are in full contact with press bed.
- Before applying load, be certain all press bed supporting pins are fully engaged.
- Always use a bearing shield when pressing bearings. Use caution when positioning work to be pressed to ensure that the item that is to be pressed cannot be dislodged or broken during press work. This may result in the item being ejected from the press at a dangerous rate of speed.
- Release hydraulic pressure before loosening any fittings.
- Maintain proper hydraulic fluid levels.
- Do not make any alterations to the press.

## OWNER/USER RESPONSIBILITY

The owner and/or user must have an understanding of the manufacturer's operating instructions and warnings before using this press. Personnel involved in the use and operation of equipment shall be careful, competent, trained, and qualified in the safe operation of the equipment and its proper use when servicing motor vehicles and their components. Warning information should be emphasized and understood.

If the operator is not fluent in English, the manufacturer's instructions and warnings shall be read to and discussed with the operator in the operator's native language by the purchaser/owner, making sure that the operator comprehends its contents.

Owner and/or user must study and maintain for future reference the manufacturer's instructions. Owner and/or user is responsible for keeping all warning labels and instruction manuals legible and intact. Replacement labels and literature are available from the manufacturers.

## INSPECTION

Visual inspection of the shop press should be made before each use of the press, checking for damaged, loose or missing parts. Each press must be inspected by a manufacturer's repair facility immediately, if subjected to an abnormal load or shock. Any press which appears to be damaged in any way, is found to be badly worn, or operates abnormally must be removed from service until necessary repairs are made by a manufacturer's authorized repair facility. It is recommended that an annual inspection of the press be made by a manufacturer's authorized repair facility and that any defective parts, decals or warning labels be replaced with manufacturer's specified parts. A list of authorized repair facilities is available from the manufacturer.

## SAFETY INSTRUCTIONS

- CHECK YOUR LOCAL, STATE AND FEDERAL REGULATIONS REGARDING THE SAFE USE OF THIS EQUIPMENT.
- Your safety is top priority. Please handle equipment with care.
- Fully retract unit and remove all items from the press bed frame.
- Support the press bed, and remove the pins.
- Raise or lower bed to desired height and reinstall press pins. Be certain pins are fully engaged in the parallel flanges of the upright columns.
- Position press on a flat, level, hard surface, preferably concrete. Make sure all nuts and bolts are tight.
- Clear the area of bystanders, especially small children, before using.
- Set the press bed to the required height. The press is most effective when the work piece is located 1 inch below the ram's retracted position. The compression stroke can include the entire 5 inch working range.
- The press is designed to exert a force on anything which is positioned beneath its ram. The work piece can pop out from under the ram at a high rate of speed and injure someone.
- Pressing Bearings: It is essential that you use the bearing shield when pressing bearings on or off.

## LIMITED WARRANTY:

SUNEX INTERNATIONAL, INC. WARRANTS TO ITS CUSTOMERS THAT THE COMPANY'S SUNEX TOOLS<sup>®</sup> BRANDED PRODUCTS ARE FREE FROM DEFECTS IN WORKMANSHIP AND MATERIALS.

Sunex International, Inc. will repair or replace its Sunex Tools<sup>®</sup> branded products which fail to give satisfactory service due to defective workmanship or materials, based upon the terms and conditions of the following described warranty plans attributed to that specific product. This product carries a ONE-YEAR warranty. During this warranty period, Sunex Tools<sup>®</sup> will repair or replace at our option any part or unit which proves to be defective in material or workmanship.

## Other important warranty information...

This warranty does not cover damage to equipment or tools arising from alteration, abuse, misuse, damage and does not cover any repairs or replacement made by anyone other than Sunex Tools<sup>®</sup> or its authorized warranty service centers. The foregoing obligation is Sunex Tools<sup>®</sup> sole liability under this or any implied warranty and under no circumstances shall we be liable for any incidental or consequential damages. **Note: Some states do not allow the exclusion or limitation of incidental or consequential damages, so the above limitation or exclusion may not apply to you.**

Return equipment or parts to Sunex Tools<sup>®</sup>, transportation prepaid. Be certain to include your name and address, evidence of the purchase date, and description of the suspected defect.

If you have any questions about warranty service, please write to Sunex Tools<sup>®</sup>. This warranty gives you specific legal rights and you may also have other rights which vary from state to state. Repair kits and replacement parts are available for many of Sunex Tools<sup>®</sup> products regardless of whether or not the product is still covered by a warranty plan.

## SHIPPING ADDRESS:

Sunex Tools  
 315 Hawkins Rd.  
 Travelers Rest, South Carolina 29690

## MAILING ADDRESS:

Sunex Tools  
 P.O. Box 4215  
 Greenville, South Carolina 29608

## PARTS LIST

ESTIMATED ASSEMBLY TIME: 30 MINUTES

Press Frame - 1

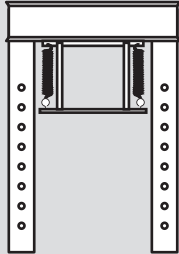

Press Bed - 1

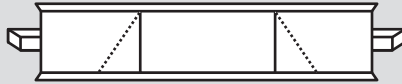

Press Feet - 2

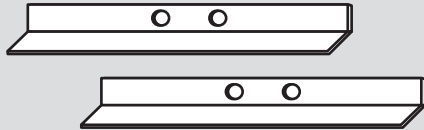

Z Bar - 1

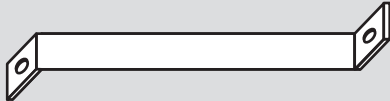

1/2"-13 x 1-1/2" Hex Head Bolts - 4



1/2" Nuts - 4



Washers - 4



5/16"-13 x 1" Hex Head Bolt - 1



Press Pins - 2

5212 - (2) 3/4" x 10" Pins  
5220 - (2) 1" x 12" Pins  
5220AH - (2) 1" x 12" Pins

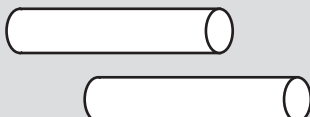

Power Unit - 1 (5212 & 5220 ONLY)

5212 - 12 Ton Power Unit  
5220 - 20 Ton Power Unit

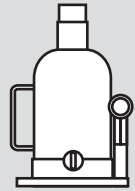

Pneumatic Power Unit - 1 (5220AH ONLY)

5220AH - 20 Ton Pneumatic Power Unit

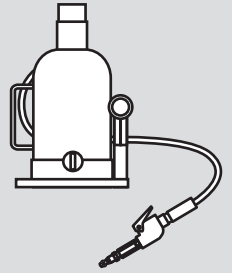

Pump Handle & Extension - 1

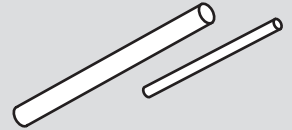

## ACCESSORIES

2" Punch - 1

*Accessory only -  
Not needed for assembly*



Bearing Shield - 1

*Accessory only -  
Not needed for assembly*



Press Plates - 2

*Accessory only -  
Not needed for assembly*

5212 - (2) 1" x 2" x 10" Plates  
5220 - (2) 3/4" x 3" x 12" Plates  
5220AH - (2) 3/4" x 3" x 12" Plates

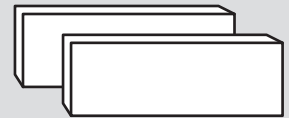

## TOOLS NEEDED

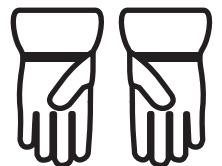
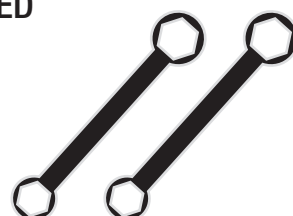

1/2" and 5/16" Box Wrenches

Examine box contents, then proceed with the following instructions.

## ASSEMBLY INSTRUCTIONS

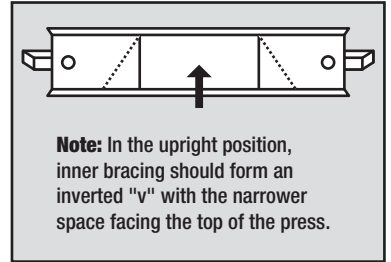
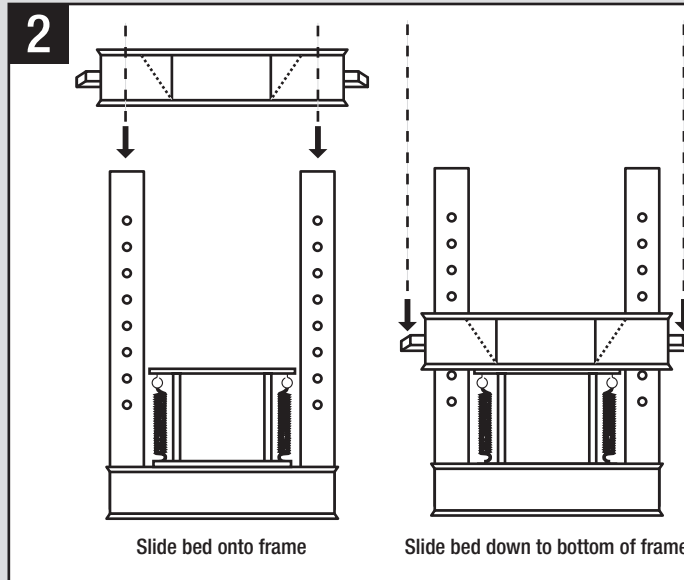
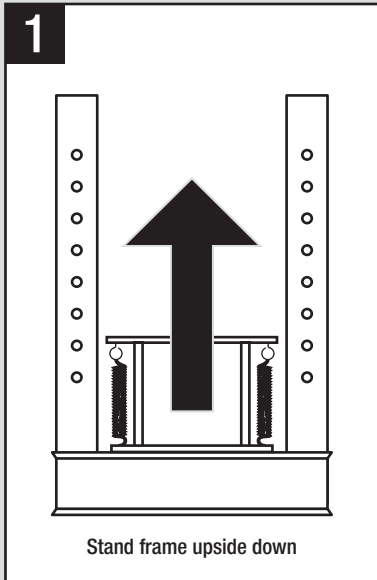

**⚠ WARNING**

Be aware of jagged edges on frame. Not all welds are smooth. Press bed can pinch or crush fingers. Wear safety gloves.

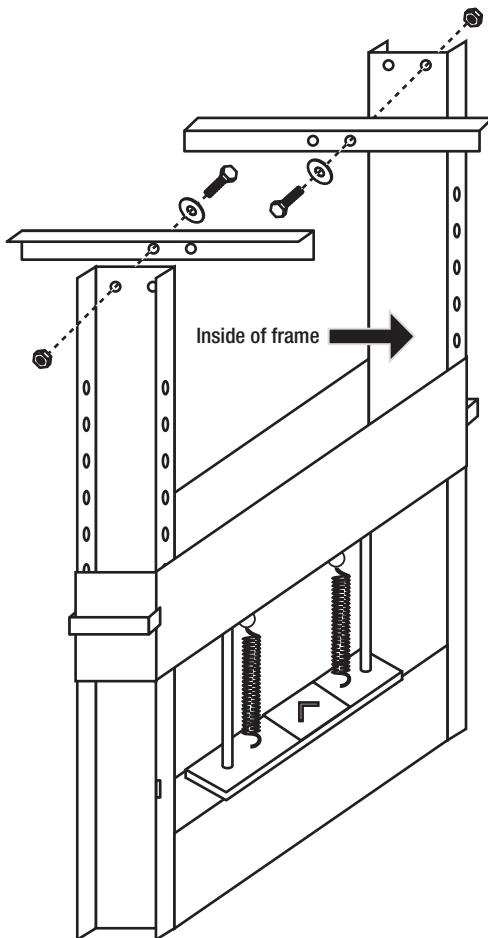
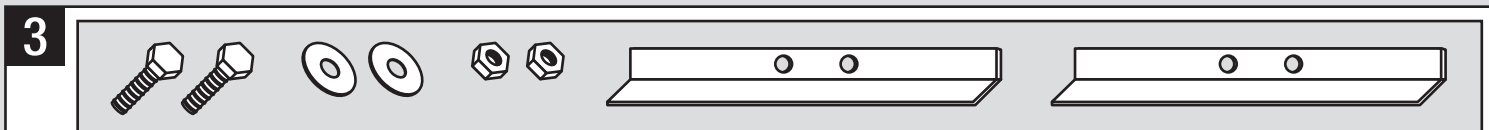

**⚠ WARNING**

Leg ends and press feet are sharp and potentially dangerous. Wear safety gloves and safety goggles.

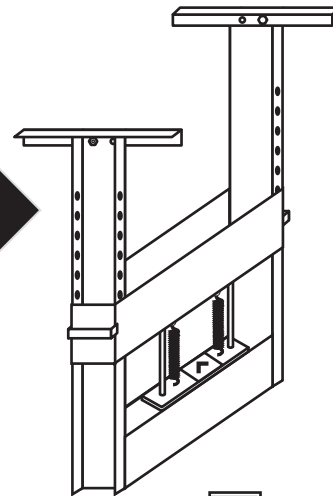

**Note:** Position press feet on each side of the press. Attach one bolt, washer and nut on each side. Bolts should be attached *OFFSET* from one another.

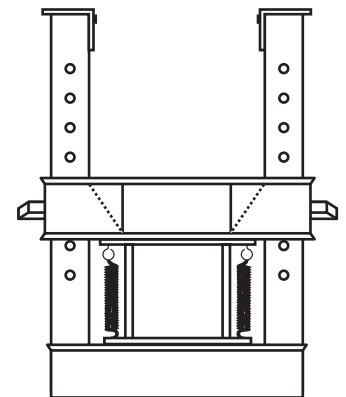

Front view

**ASSEMBLY INSTRUCTIONS CONTINUED**

**4**

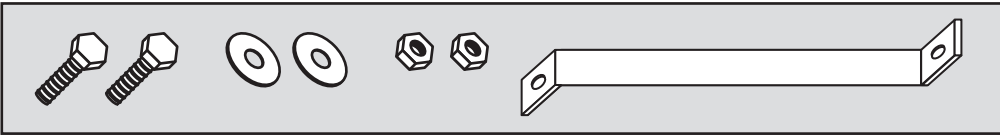

Use bolts, washers and nuts to attach Z Bar to both sides of the press.

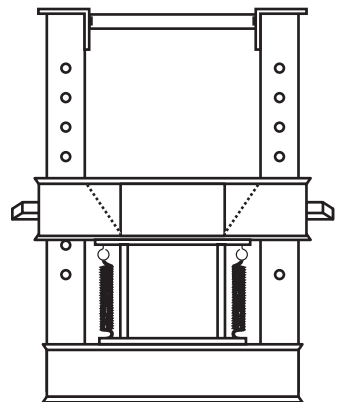
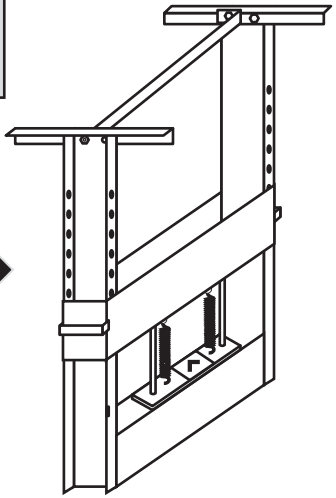
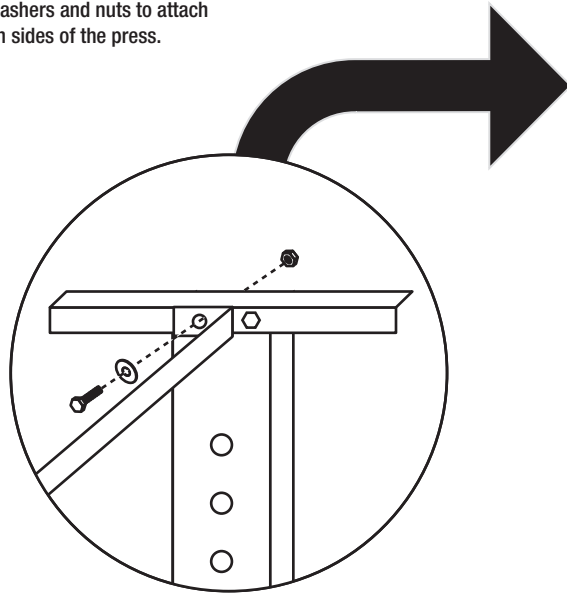
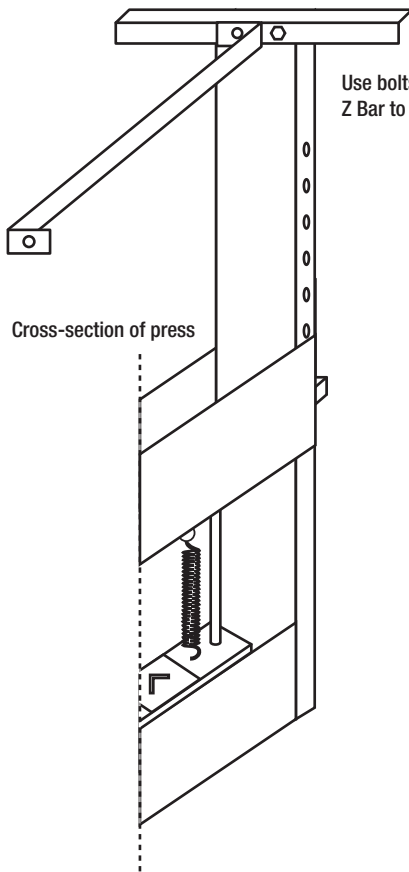

Front view

**Note:** Check all bolts for tightness. If press rocks, or is not level, loosen press feet slightly to compensate and retighten.

**5**

**⚠ WARNING**

Bed must be at the **BOTTOM** of the frame before proceeding to the next step.

**Note:** When sliding bed to frame bottom, **DO NOT** use bed handles.

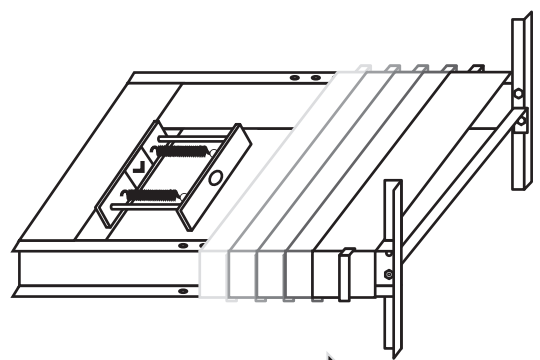
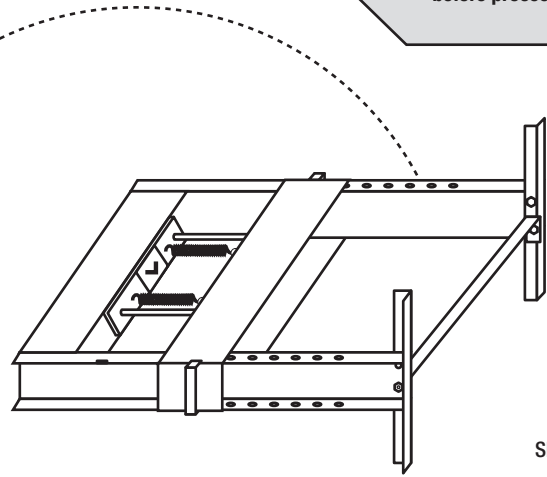
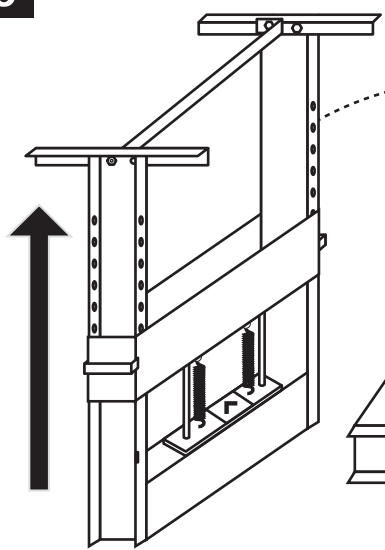

Slide bed down to bottom of frame →

## ASSEMBLY INSTRUCTIONS CONTINUED

6

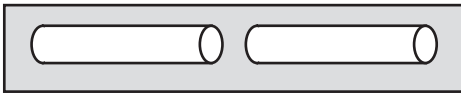

### ⚠ WARNING

Pins must be COMPLETELY through BOTH SIDES of frame.

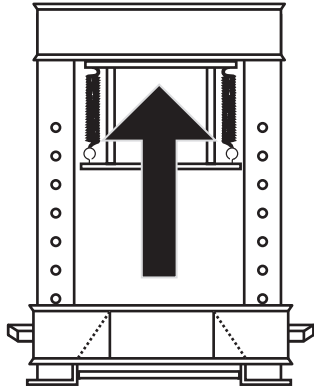

Stand unit upright

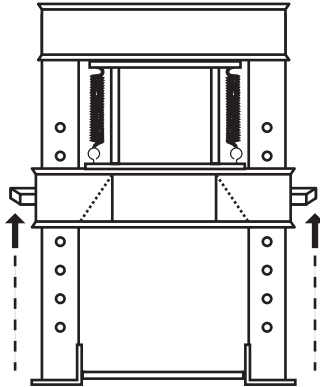

Slide bed above holes and *hold in place*

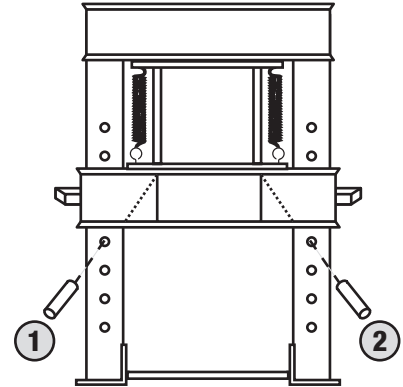

Secure pins underneath bed, one at a time

## PROCEDURE FOR BLEEDING AIR

7

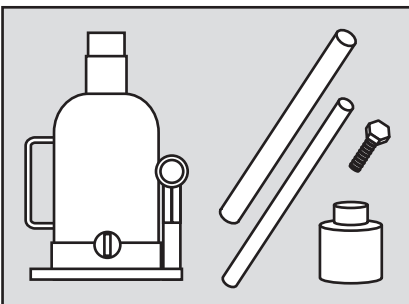

1. Align power unit with "V" in top plate (opening in "V" faces the front side of the press).

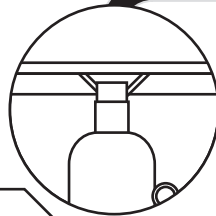

2. Insert punch into receptacle UNDER bottom plate.

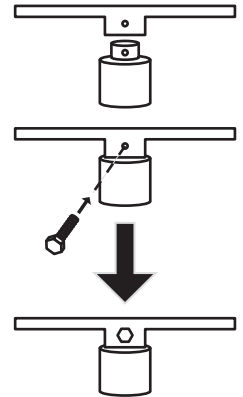

3. Tighten screw to secure punch.

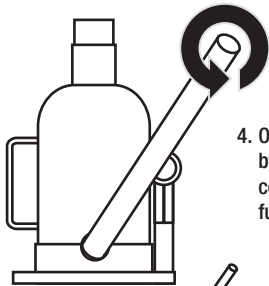

4. Open the release valve by rotating the handle counterclockwise ONE full turn.

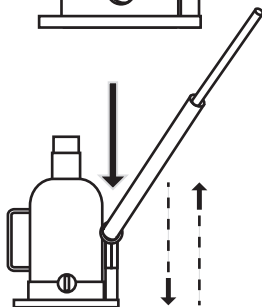

5. Place pump in cradle. Pump 6 full strokes to purge air.

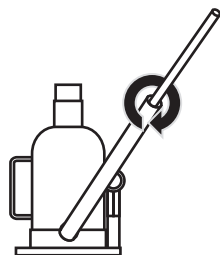

6. Close valve.

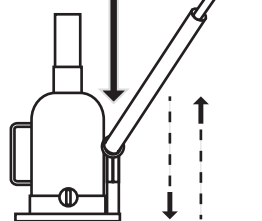

7. Pump until unit reaches full extension. Keep pumping under load to purge all air.

**Note:** If the unit responds immediately to pump action, it is free of air and ready for operation. If not, repeat procedure.



8. Open valve and push ram to its lowest position.



9. Close valve and operate normally.

## PUMP INSTRUCTIONS FOR 5212 & 5220

### 8

1. Place the handle on the release valve and rotate clockwise until the valve is closed (hand tighten only).

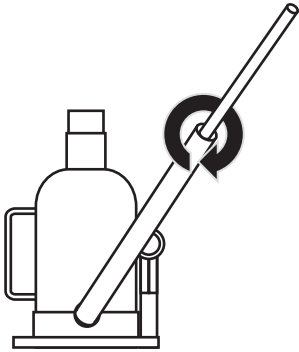

2. Place the pump handle in the cradle. Move pump handle up and down to lower the carriage and apply force to the item being pressed.

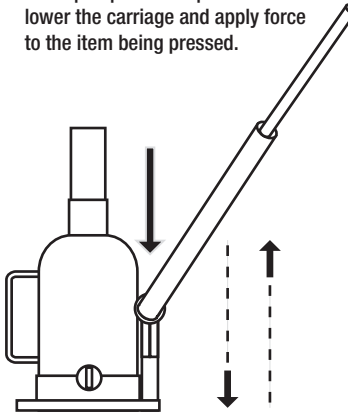

3. To release pressure, remove the pump handle from the cradle and use the handle to slowly turn the release valve counterclockwise. The power unit cylinder will retract and the press cradle will return to the stored position.

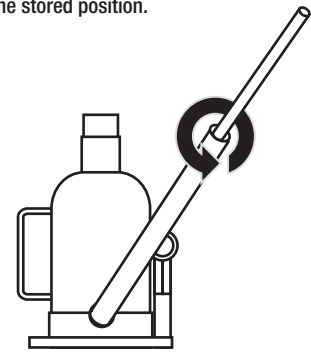

**Note:** When not in use, store power unit with the piston in the fully retracted position and the release valve closed.

## PUMP INSTRUCTIONS FOR 5220AH

### 8-AH

#### TO OPERATE MANUALLY

5220AH can be operated manually or with pneumatic/ hydraulic assist. See step 8 (#1, 2, & 3) for manual operating instructions.

#### TO OPERATE WITH PNEUMATIC/ HYDRAULIC ASSIST

After step 7 (#9): Ensure the oil level is just below the oil filler plug hole. Re-install the oil filler plug. Pour a teaspoon of good quality, air tool lubricant into the air supply inlet of the lift control valve.

Connect to air supply and operate for 3 seconds to evenly distribute lubricant. Check to ensure that the pump operates smoothly before putting into service. Replace worn or damaged parts and assemblies as needed with manufacturer's authorized replacement parts.

1. Place the handle on the release valve and rotate clockwise until the valve is closed (hand tighten only).

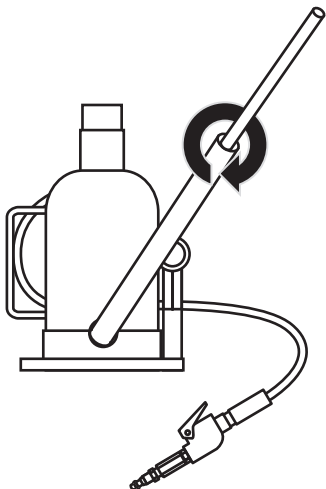

2. To begin pneumatic operation, squeeze air hose trigger until ram comes into contact with the item to be pressed.

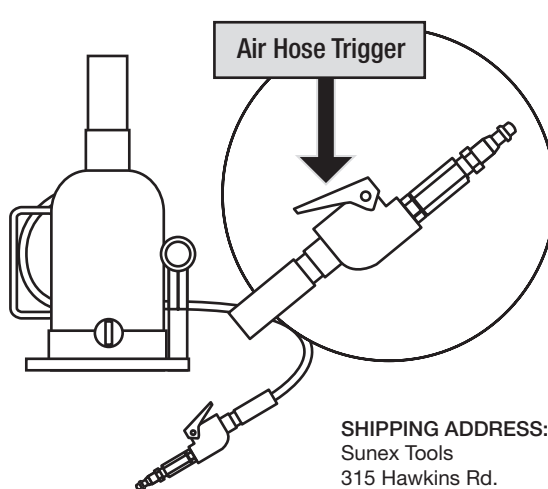

3. To end pneumatic operation, release the grip on the air hose trigger.

#### **⚠ WARNING**

Never wire, clamp or otherwise disable the lift control valve to function by any means other than by using the operator's hand.

**SHIPPING ADDRESS:**  
Sunex Tools  
315 Hawkins Rd.  
Travelers Rest, South Carolina 29690

**MAILING ADDRESS:**  
Sunex Tools  
P.O. Box 4215  
Greenville, South Carolina 29608

## REPLACEMENT PARTS LIST

5212 - 12 Ton Manual Shop Press

5220 - 20 Ton Manual Shop Press

5220AH - 20 Ton Manual Shop Press with Pneumatic/ Hydraulic Power Unit

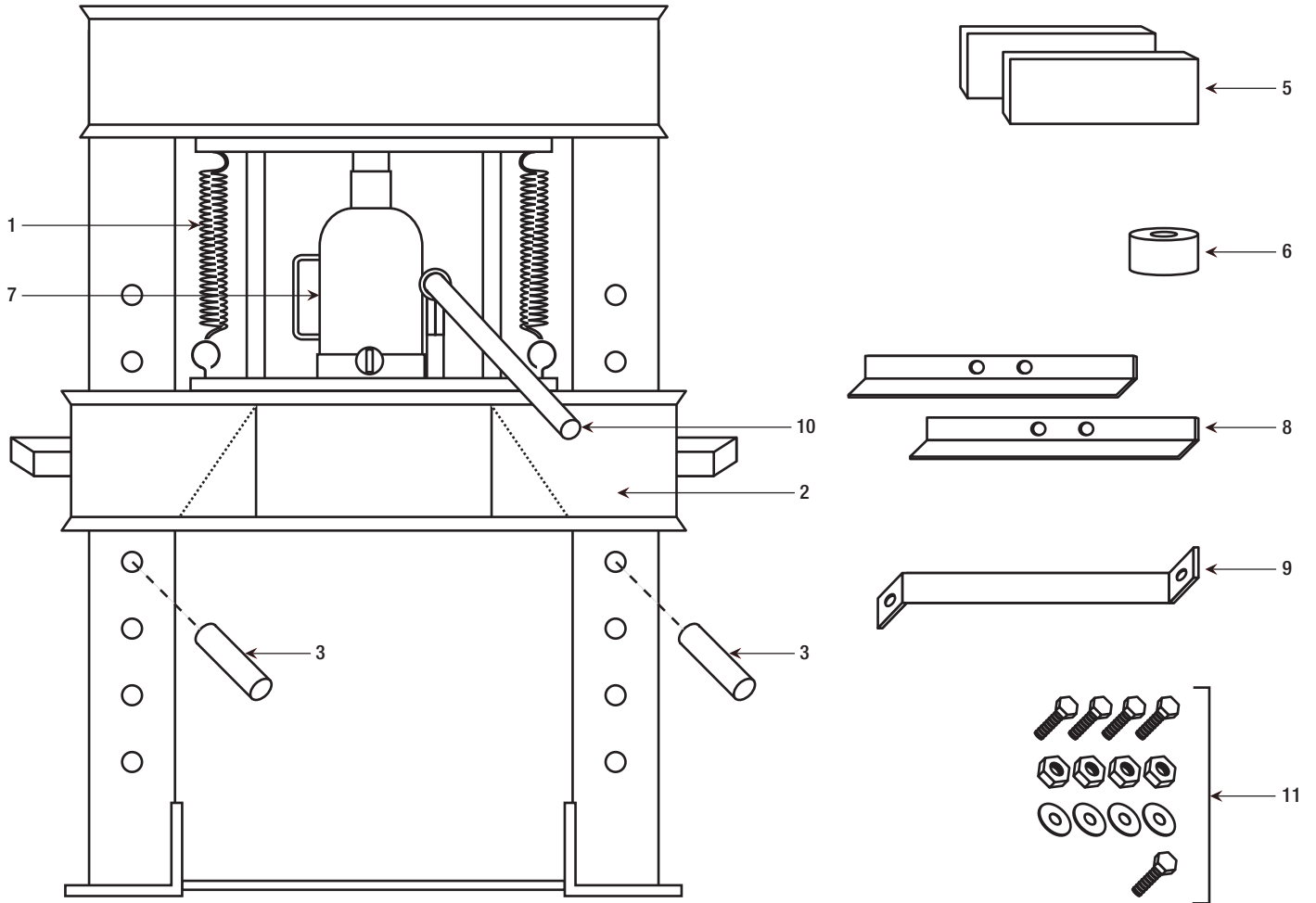

ITEM NO.	SUNEX PART NO.	DESCRIPTION	QTY.
1	RS345009	Spring	2
2		Press Bed (5212)	1
		Press Bed (5220 & 5220AH)	
3	RS12PP	Press Pin (5212)	2
	RS550034	Press Pin (5220 & 5220AH)	2
4	RS310012	Pushing Adapter	1
5	RS550041	Press Plate	2
6	RSBS1	Bearing Shield	1
7	912P	12 Ton Power Unit (includes handle)	1
	920P	20 Ton Power Unit (includes handle)	1
	4920CAH	20 Ton Pneumatic Power Unit (includes handle)	1

ITEM NO.	SUNEX PART NO.	DESCRIPTION	QTY.
8	RS12FT	Press Feet (5212)	2
	RS20FT	Press Feet (5220 & 5220AH)	2
9	RS550049	Z Bar (5212)	1
	RS550051	Z Bar (5220 & 5220AH)	1
10	RS49HDL12	Power Unit Handle	1
11	RS5212BK	Press Hardware Kit	1 set
		1/2"-13 x 1-1/2" Hex Head Bolt	4
		1/2" Nut	4
		Washer	4
		5/16"-13 x 1-1" Hex Head Bolt	1

Only items identified by part number are available separately.