



SHOP PRESS OPERATION MANUAL

52100 - 100 Ton Air Hydraulic Shop Press

52150 - 150 Ton Air Hydraulic Shop Press

PRESS SPECIFICATIONS

Sunex Part No.	A	B	C	D	E	F	G	H	I	J
52100	78"	34"	40"	15-1/2"	5"	1-1/4"	HASKEL AIR	Y	Y	Y (2)
52150	78-1/2"	36"	48"	18-1/4"	5"	1-1/4"	HASKEL AIR	Y	Y	Y (2)

- A - Total Height
- B - Inside Width
- C - Press Feet Length
- D - Bed Width
- E - Stroke (ram travel distance from fully retracted position to fully extended position)
- F - Pin Diameter
- G - Motor Control
- H - PB Winch
- I - Sliding Head
- J - Press Plates Included

SAFETY INFORMATION



THIS OPERATING MANUAL CONTAINS IMPORTANT SAFETY INFORMATION. READ CAREFULLY AND UNDERSTAND ALL INFORMATION BEFORE OPERATING THIS TOOL. SAVE THIS MANUAL FOR FUTURE USE.

⚠ WARNING

This symbol alerts you to the possibility of serious injury or death if instructions are not followed.

⚠ CAUTION

This symbol alerts you to the possibility of damage to or destruction of equipment if instructions are not followed.

⚠ WARNING

Failure to heed these warnings may result in loss of load, damage to the press and/or failure resulting in property damage, personal or fatal injury. This operating manual contains important details concerning the safe operation of this tool. The user must read and understand these details before any use of the tool. This manual must be retained for future reference.

ing the safe operation of this tool. The user must read and understand these details before any use of the tool. This manual must be retained for future reference.

- Read, study, and understand all instruction manuals packed with this press before operating.
- Always wear safety goggles.
- Parts being pressed may splinter, shatter, or be ejected from the press at a dangerous rate of speed. Because of the variety of press applications, it is your responsibility to always use adequate guards and wear eye protection and heavy protective clothing when operating the press.
- Visual inspection should be made before each use of the press, checking for signs of cracked welds, bent bed pins, loose or missing bolts, leaks, or any other structural damage.
- Do not go near leaks. High pressure oil can puncture skin and cause serious injury, gangrene, or death. If injured, seek emergency medical help. Immediate surgery is required to remove oil.
- Keep hands and fingers out of the press and away from parts that may shift and pinch. Do not stand in front of work area when load is applied.
- Always use an accurate pressure gauge to measure pressing force.
- Do not exceed the rated capacity of this press.
- Never tamper with hydraulic system pressure settings.
- Do not substitute bolts, pins or any part of the components. Use only genuine factory replacement parts.
- Always center load on ram plunger. Offset loads can damage ram and may cause load to eject at a dangerous rate of speed.
- Remove all loads from press bed before attempting to adjust bed height. Beware of possibility of falling bed.
- Press only on loads supported by press bed and included press plates. Do not support loads on floor or press frame.
- When using any accessories such as arbor plates, be certain they are centered on press bed and are in full contact with press bed.
- Before applying load, be certain all press bed supporting pins are fully engaged.
- Use caution when positioning work to be pressed to ensure that the item that is to be pressed cannot be dislodged or broken during press work. This may result in the item being ejected from the press at a dangerous rate of speed.
- Release hydraulic pressure before loosening any fittings.
- Maintain proper hydraulic fluid levels.
- Do not make any alterations to the press.

OWNER/USER RESPONSIBILITY

The owner and/or user must have an understanding of the manufacturer's operating instructions and warnings before using this press. Personnel involved in the use and operation of equipment shall be careful, competent, trained, and qualified in the safe operation of the equipment and its proper use when servicing motor vehicles and their components. Warning information should be emphasized and understood.

If the operator is not fluent in English, the manufacturer's instructions and warnings shall be read to and discussed with the operator in the operator's native language by the purchaser/owner, making sure that the operator comprehends its contents.

Owner and/or user must study and maintain for future reference the manufacturer's instructions. Owner and/or user is responsible for keeping all warning labels and instruction manuals legible and intact. Replacement labels and literature are available from the manufacturers.

INSPECTION

Visual inspection of the shop press should be made before each use of the press, checking for damaged, loose or missing parts. Each press must be inspected by a manufacturer's repair facility immediately, if subjected to an abnormal load or shock. Any press which appears to be damaged in any way, is found to be badly worn, or operates abnormally must be removed from service until necessary repairs are made by a manufacturer's authorized repair facility. It is recommended that an annual inspection of the press be made by a manufacturer's authorized repair facility and that any defective parts, decals or warning labels be replaced with manufacturer's specified parts. A list of authorized repair facilities is available from the manufacturer.

SAFETY INSTRUCTIONS

- CHECK YOUR LOCAL, STATE AND FEDERAL REGULATIONS REGARDING THE SAFE USE OF THIS EQUIPMENT.
- Your safety is top priority. Please handle equipment with care.
- Fully retract unit and remove all items from the press bed frame.
- Support the press bed, and remove the pins.
- Raise or lower bed to desired height and reinstall press pins. Be certain pins are fully engaged in the parallel flanges of the upright columns.
- Position press on a flat, level, hard surface, preferably concrete. Make sure all nuts and bolts are tight.
- Clear the area of bystanders, especially small children, before using.
- Set the press bed to the required height. The press is most effective when the work piece is located 1 inch below the ram's retracted position. The compression stroke can include the entire 5 inch working range.
- The press is designed to exert a force on anything which is positioned beneath its ram. The work piece can pop out from under the ram at a high rate of speed and injure someone.

LIMITED WARRANTY:

SUNEX INTERNATIONAL, INC. WARRANTS TO ITS CUSTOMERS THAT THE COMPANY'S SUNEX TOOLS[®] BRANDED PRODUCTS ARE FREE FROM DEFECTS IN WORKMANSHIP AND MATERIALS.

Sunex International, Inc. will repair or replace its Sunex Tools[®] branded products which fail to give satisfactory service due to defective workmanship or materials, based upon the terms and conditions of the following described warranty plans attributed to that specific product. This product carries a ONE-YEAR warranty. During this warranty period, Sunex Tools[®] will repair or replace at our option any part or unit which proves to be defective in material or workmanship.

Other important warranty information....

This warranty does not cover damage to equipment or tools arising from alteration, abuse, misuse, damage and does not cover any repairs or replacement made by anyone other than Sunex Tools[®] or its authorized warranty service centers. The foregoing obligation is Sunex Tools[®] sole liability under this or any implied warranty and under no circumstances shall we be liable for any incidental or consequential damages. **Note: Some states do not allow the exclusion or limitation of incidental or consequential damages, so the above limitation or exclusion may not apply to you.**

Return equipment or parts to Sunex Tools[®], transportation prepaid. Be certain to include your name and address, evidence of the purchase date, and description of the suspected defect.

If you have any questions about warranty service, please write to Sunex Tools[®]. This warranty gives you specific legal rights and you may also have other rights which vary from state to state. Repair kits and replacement parts are available for many of Sunex Tools[®] products regardless of whether or not the product is still covered by a warranty plan.

SHIPPING ADDRESS:

Sunex Tools
 315 Hawkins Rd.
 Travelers Rest, South Carolina 29690

MAILING ADDRESS:

Sunex Tools
 P.O. Box 4215
 Greenville, South Carolina 29608

SPECIFICATIONS & OPERATING INSTRUCTIONS

AIR SUPPLY

130 PSI recommended for best operation.

FLUID LEVELS

Use AW-32 hydraulic oil ONLY and fill to level indicated on tank (just below fill plug).

WATER FILTER

Empty water and replace filter as recommended in manufacturer's instructions.

CAUTION

Excess moisture in air supply can shorten air motor life and cause erratic operation.

SLIDING HEAD

Ram can be moved from left to right.

CAUTION

Do not attempt to move ram while press is in operation.

Note:

- RETAIN THIS MANUAL FOR FUTURE REFERENCE.
- RETAIN AIR MOTOR AND WINCH MANUALS FOR FUTURE REFERENCE.
- REFER TO AIR MOTOR MANUAL FOR MAINTENANCE INSTRUCTIONS.

OPERATING INSTRUCTIONS

CAUTION

Remove all items from press bed before operating winch.

WARNING

Do not operate press without all press bed pins in place. The winch and winch cable are designed to support the weight of the press bed only. Using the press without the pins in place can result in damage to the press, personal injury, or death.

TO RAISE OR LOWER PRESS BED

- Once press bed has been positioned and all pins are in place, release tension on cable so press bed is supported entirely by the press pins.
- Move winch handle toward back of press to lower bed.
- Move winch handle toward front of press to raise bed.

TO RETRACT RAM

1. Open release valve by turning counter-clockwise.
2. Move control valve handle to extreme right.

TO LOWER RAM

1. Move control valve handle to the left.

TO CONTROL RAM SPEED

- Open release valve for faster ram speed.
- Close release valve when ram contacts work surface.
- Ram will not apply pressure until release valve is closed.

Keep air control valve handle in center position when press is not in use.

CAUTION

Do not leave air supply connected when press is not in use. Pressure will force oil into air lines and air motor.

WARNING

Do not overextend ram. This device is equipped with a safety release valve; however, overextending the ram can result in damage to equipment, personal injury, or death.

NOTES

PARTS DIAGRAM

FRONT VIEW

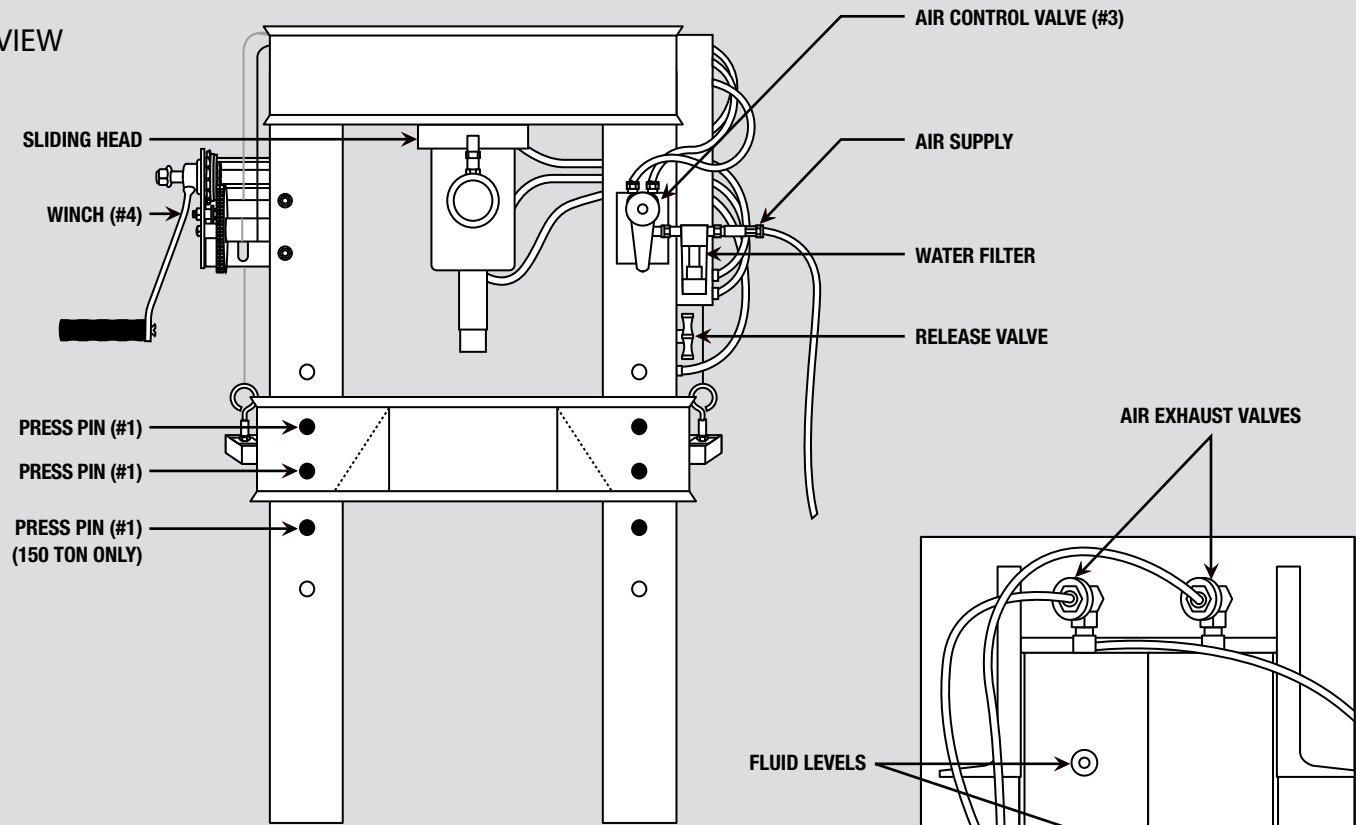

BACK VIEW

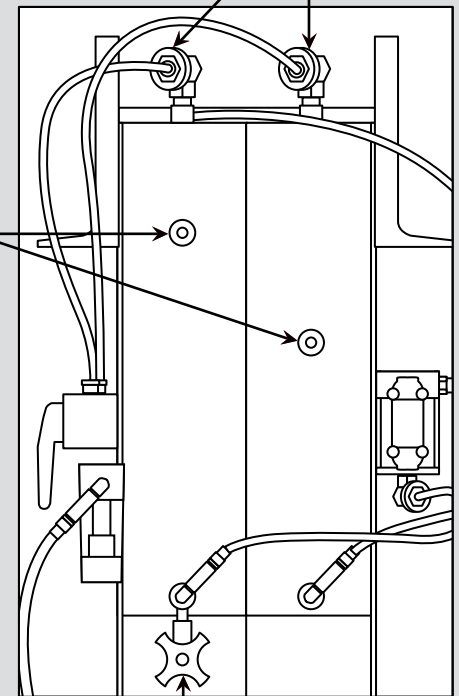
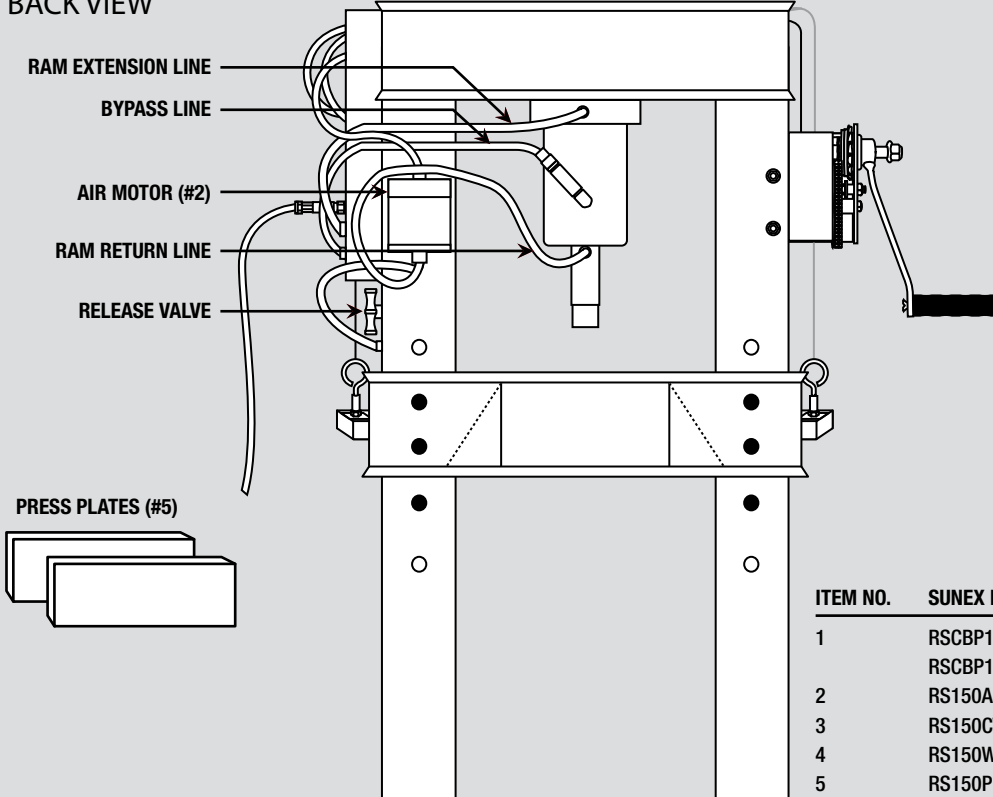

ITEM NO.	SUNEX PART NO.	DESCRIPTION	QTY.
1	RSCBP1225	Press Pin (100 Ton Press)	4
	RSCBP1225	Press Pin (150 Ton Press)	6
2	RS150AM	Air Motor	1
3	RS150CV	Rexroth Control Valve	1
4	RS150W	Winch (only)	1
5	RS150PP	Press Plate	2