



SHOP PRESS ASSEMBLY INSTRUCTIONS

5240AO - 40 Ton Air Over Shop Press

PRESS SPECIFICATIONS

Sunex Part No.	A	B	C	D	E	F	G	H
5240AO	74.25"	32"	29.75"	12"	6.75"	1.25"	Air Assist	Y(2)

A - Total Height

B - Inside Width

C - Press Feet Length

D - Bed Width

E - Stroke (ram travel distance from fully retracted position to fully extended position)

F - Pin Diameter

G - Motor Control

H - Press Plates Included

SAFETY INFORMATION



THIS OPERATING MANUAL CONTAINS IMPORTANT SAFETY INFORMATION. READ CAREFULLY AND UNDERSTAND ALL INFORMATION BEFORE OPERATING THIS TOOL. SAVE THIS MANUAL FOR FUTURE USE.

WARNING

This symbol alerts you to the possibility of serious injury or death if instructions are not followed.

CAUTION

This symbol alerts you to the possibility of damage to or destruction of equipment if instructions are not followed.

WARNING

Failure to heed these warnings may result in loss of load, damage to the press and/or failure resulting in property damage, personal or fatal injury. This operating manual contains important details concern-

ing the safe operation of this tool. The user must read and understand these details before any use of the tool. This manual must be retained for future reference.

- Read, study, and understand all instruction manuals packed with this press before operating.
- Always wear safety goggles.
- Parts being pressed may splinter, shatter, or be ejected from the press at a dangerous rate of speed. Because of the variety of press applications, it is your responsibility to always use adequate guards and wear eye protection and heavy protective clothing when operating the press.
- Visual inspection should be made before each use of the press, checking for signs of cracked welds, bent bed pins, loose or missing bolts, leaks, or any other structural damage.
- Do not go near leaks. High pressure oil can puncture skin and cause serious injury, gangrene, or death. If injured, seek emergency medical help. Immediate surgery is required to remove oil.
- Keep hands and fingers out of the press and away from parts that may shift and pinch. Do not stand in front of work area when load is applied.
- Always use an accurate pressure gauge to measure pressing force.
- Do not exceed the rated capacity of this press.
- Never tamper with hydraulic system pressure settings.
- Do not substitute bolts, pins or any part of the components. Use only genuine factory replacement parts.
- Always center load on ram plunger. Offset loads can damage ram and may cause load to eject at a dangerous rate of speed.
- Remove all loads from press bed before attempting to adjust bed height. Beware of possibility of falling bed.
- Press only on loads supported by press bed and included press plates. Do not support loads on floor or press frame.
- When using any accessories such as arbor plates, be certain they are centered on press bed and are in full contact with press bed.
- Before applying load, be certain all press bed supporting pins are fully engaged.
- Always use a bearing shield when pressing bearings. Use caution when positioning work to be pressed to ensure that the item that is to be pressed cannot be dislodged or broken during press work. This may result in the item being ejected from the press at a dangerous rate of speed.
- Release hydraulic pressure before loosening any fittings.
- Maintain proper hydraulic fluid levels.
- Do not make any alterations to the press.

OWNER/USER RESPONSIBILITY

The owner and/or user must have an understanding of the manufacturer's operating instructions and warnings before using this press. Personnel involved in the use and operation of equipment shall be careful, competent, trained, and qualified in the safe operation of the equipment and its proper use when servicing motor vehicles and their components. Warning information should be emphasized and understood.

If the operator is not fluent in English, the manufacturer's instructions and warnings shall be read to and discussed with the operator in the operator's native language by the purchaser/owner, making sure that the operator comprehends its contents.

Owner and/or user must study and maintain for future reference the manufacturer's instructions. Owner and/or user is responsible for keeping all warning labels and instruction manuals legible and intact. Replacement labels and literature are available from the manufacturers.

INSPECTION

Visual inspection of the shop press should be made before each use of the press, checking for damaged, loose or missing parts. Each press must be inspected by a manufacturer's repair facility immediately, if subjected to an abnormal load or shock. Any press which appears to be damaged in any way, is found to be badly worn, or operates abnormally must be removed from service until necessary repairs are made by a manufacturer's authorized repair facility. It is recommended that an annual inspection of the press be made by a manufacturer's authorized repair facility and that any defective parts, decals or warning labels be replaced with manufacturer's specified parts. A list of authorized repair facilities is available from the manufacturer.

SAFETY INSTRUCTIONS

- CHECK YOUR LOCAL, STATE AND FEDERAL REGULATIONS REGARDING THE SAFE USE OF THIS EQUIPMENT.
- Your safety is top priority. Please handle equipment with care.
- Fully retract unit and remove all items from the press bed frame.
- Support the press bed, and remove the pins.
- Raise or lower bed to desired height and reinstall press pins. Be certain pins are fully engaged in the parallel flanges of the upright columns.
- Position press on a flat, level, hard surface, preferably concrete. Make sure all nuts and bolts are tight.
- Clear the area of bystanders, especially small children, before using.
- Set the press bed to the required height. The press is most effective when the work piece is located 1 inch below the ram's retracted position. The compression stroke can include the entire 5 inch working range.
- The press is designed to exert a force on anything which is positioned beneath its ram. The work piece can pop out from under the ram at a high rate of speed and injure someone.
- Pressing Bearings: It is essential that you use the bearing shield when pressing bearings on or off.

LIMITED WARRANTY:

SUNEX INTERNATIONAL, INC. WARRANTS TO ITS CUSTOMERS THAT THE COMPANY'S SUNEX TOOLS[®] BRANDED PRODUCTS ARE FREE FROM DEFECTS IN WORKMANSHIP AND MATERIALS.

Sunex International, Inc. will repair or replace its Sunex Tools[®] branded products which fail to give satisfactory service due to defective workmanship or materials, based upon the terms and conditions of the following described warranty plans attributed to that specific product. This product carries a ONE-YEAR warranty. During this warranty period, Sunex Tools[®] will repair or replace at our option any part or unit which proves to be defective in material or workmanship.

Other important warranty information....

This warranty does not cover damage to equipment or tools arising from alteration, abuse, misuse, damage and does not cover any repairs or replacement made by anyone other than Sunex Tools[®] or its authorized warranty service centers. The foregoing obligation is Sunex Tools[®] sole liability under this or any implied warranty and under no circumstances shall we be liable for any incidental or consequential damages. **Note: Some states do not allow the exclusion or limitation of incidental or consequential damages, so the above limitation or exclusion may not apply to you.**

Return equipment or parts to Sunex Tools[®], transportation prepaid. Be certain to include your name and address, evidence of the purchase date, and description of the suspected defect.

If you have any questions about warranty service, please write to Sunex Tools[®]. This warranty gives you specific legal rights and you may also have other rights which vary from state to state. Repair kits and replacement parts are available for many of Sunex Tools[®] products regardless of whether or not the product is still covered by a warranty plan.

SHIPPING ADDRESS:

Sunex Tools
 315 Hawkins Rd.
 Travelers Rest, South Carolina 29690

MAILING ADDRESS:

Sunex Tools
 P.O. Box 4215
 Greenville, South Carolina 29608

PARTS LIST

ESTIMATED ASSEMBLY TIME: 30 MINUTES

Press Frame - 1

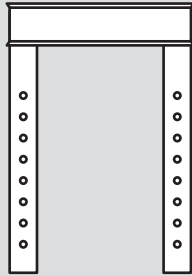

Press Bed - 1



Press Feet - 2

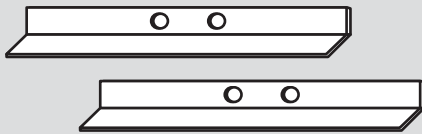

Z Bar - 1



1/2"-13 x 1-1/2"
Hex Head Bolts - 10

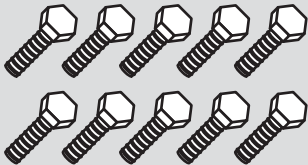

1/2" Nuts - 10

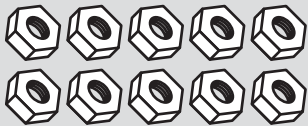

Washers - 10

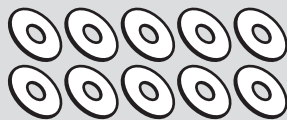

1-1/4" x 14" Press Pins - 4

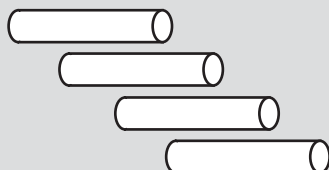

Air Motor
Pump and Ram - 1

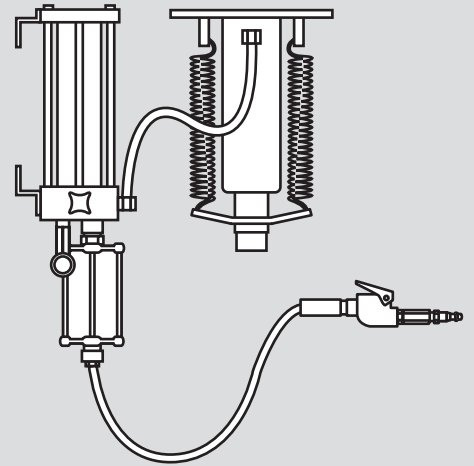

Pump Extension Handle - 1



ACCESSORIES

1" x 3" x 14"
Press Plates - 2

*Accessory only -
Not needed for assembly*

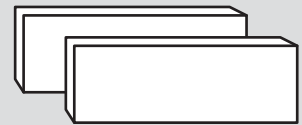

Pushing Adapter - 1

*Accessory only -
Not needed for assembly*



Bearing Shield - 1

*Accessory only -
Not needed for assembly*



TOOLS NEEDED

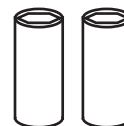

3/4" and 9/16" sockets and wrenches

Examine box contents, then proceed with the following instructions.

ASSEMBLY INSTRUCTIONS

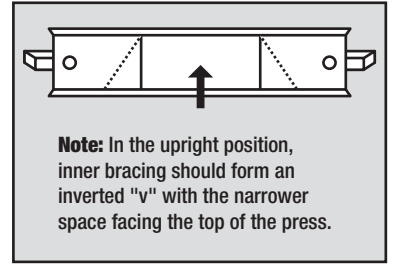
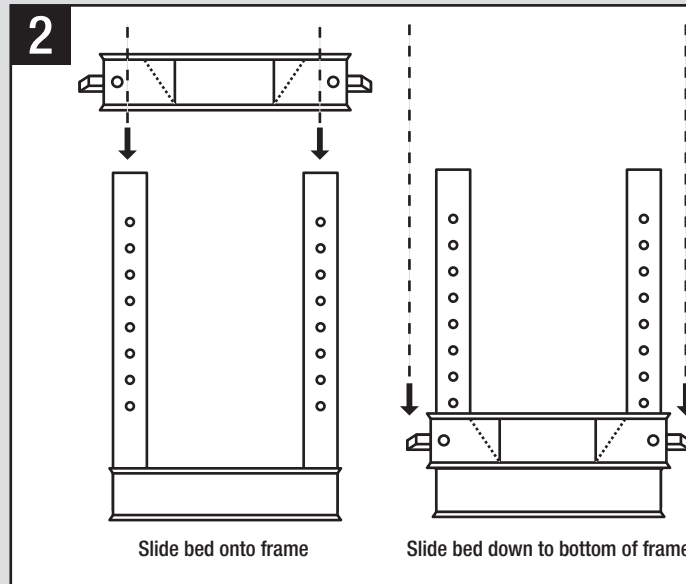
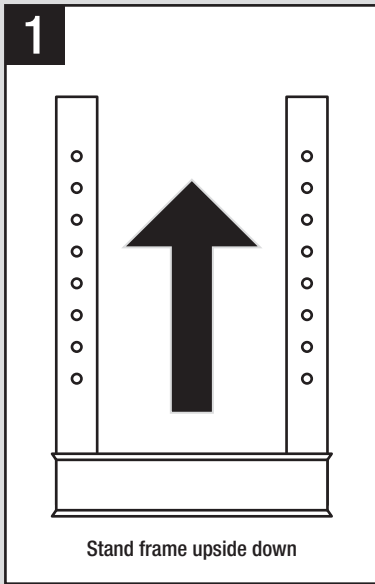

⚠ WARNING

Be aware of jagged edges on frame. Not all welds are smooth. Press bed can pinch or crush fingers. Wear safety gloves.

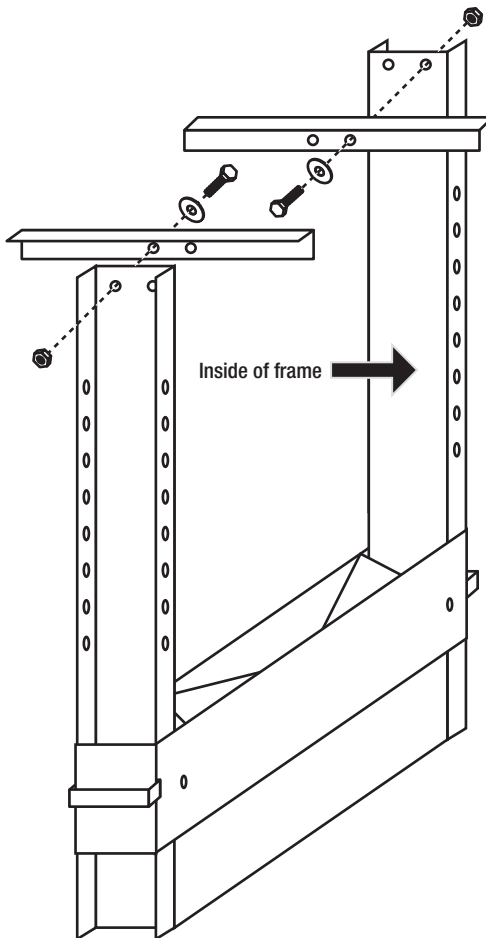
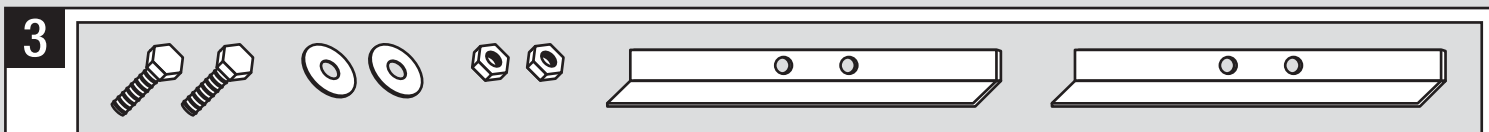

⚠ WARNING

Leg ends and press feet are sharp and potentially dangerous. Wear safety gloves and safety goggles.

Note: Position press feet on each side of the press. Attach one bolt, washer and nut on each side. Bolts should be attached *OFFSET* from one another.

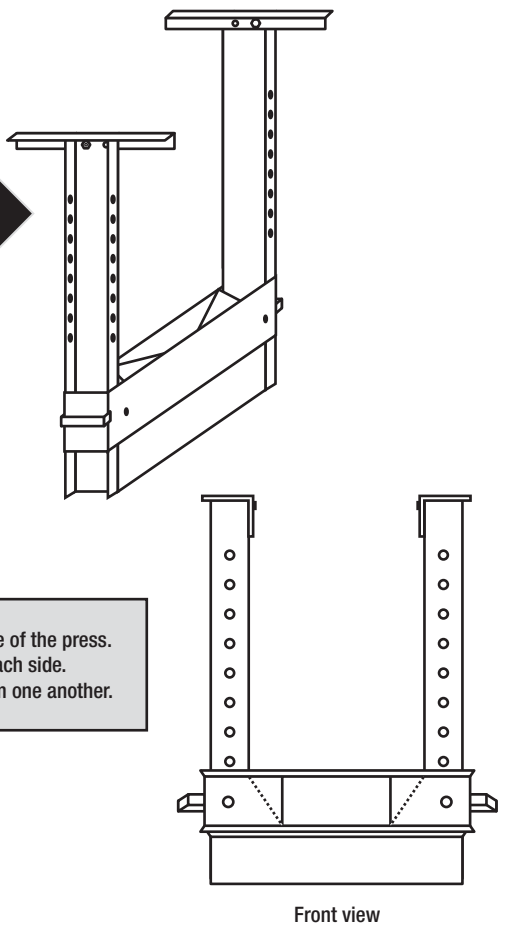

ASSEMBLY INSTRUCTIONS CONTINUED

4

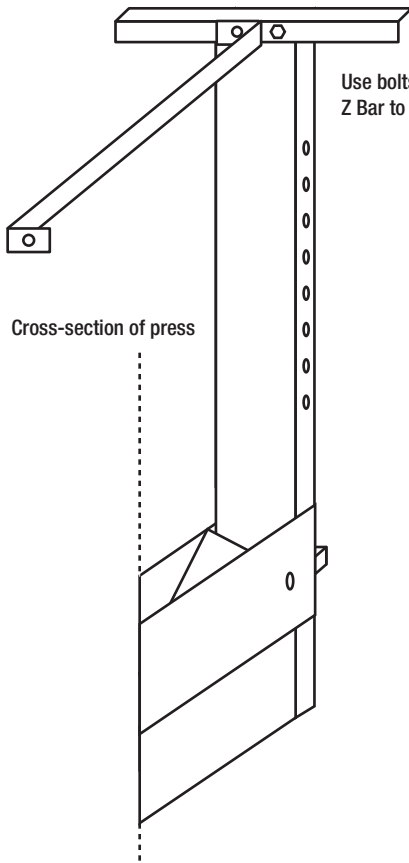
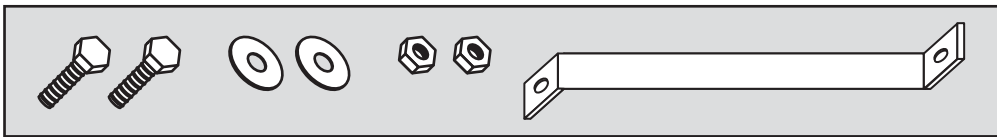

Use bolts, washers and nuts to attach Z Bar to both sides of the press.

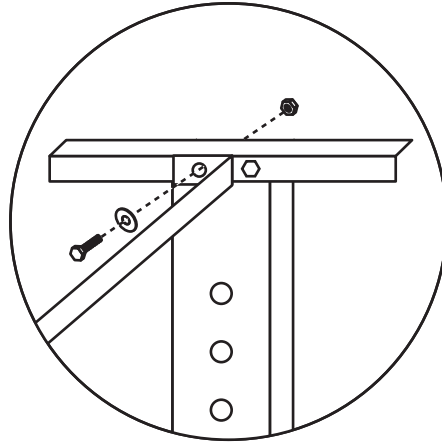

Note: Check all bolts for tightness. If press rocks, or is not level, loosen press feet slightly to compensate and retighten.

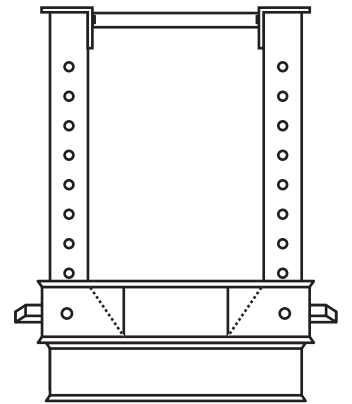
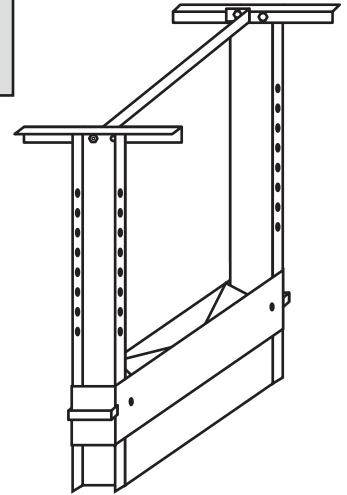

Front view

5

⚠ WARNING

Bed must be at the **BOTTOM** of the frame before proceeding to the next step.

Note: When sliding bed to frame bottom, **DO NOT** use bed handles.

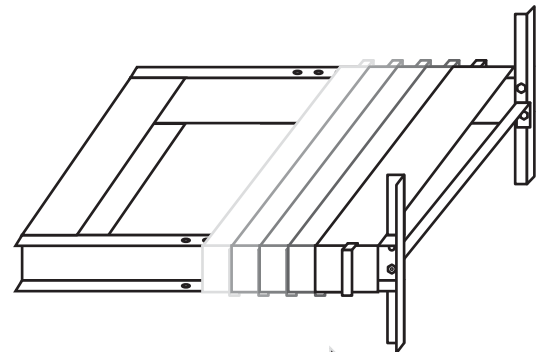
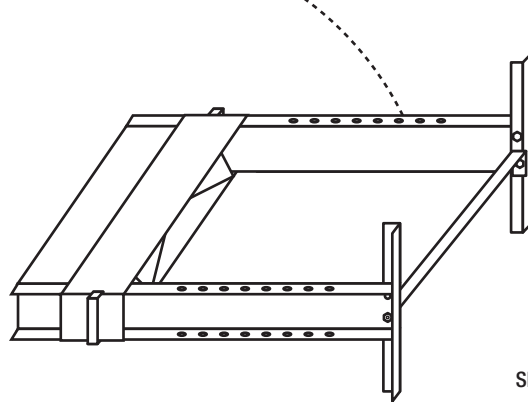
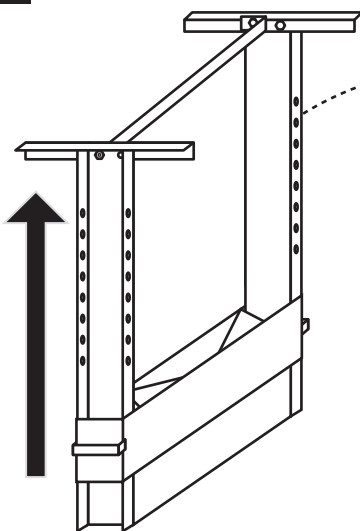

Slide bed down to bottom of frame →

ASSEMBLY INSTRUCTIONS CONTINUED

6

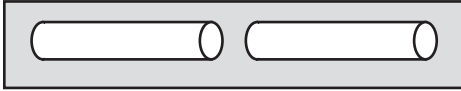

⚠ WARNING

Pins must be COMPLETELY through BOTH SIDES of frame.

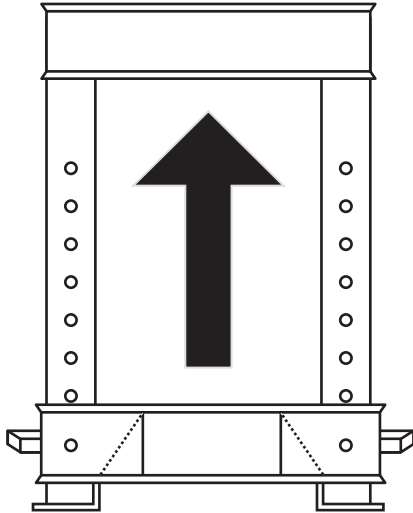

Stand unit upright

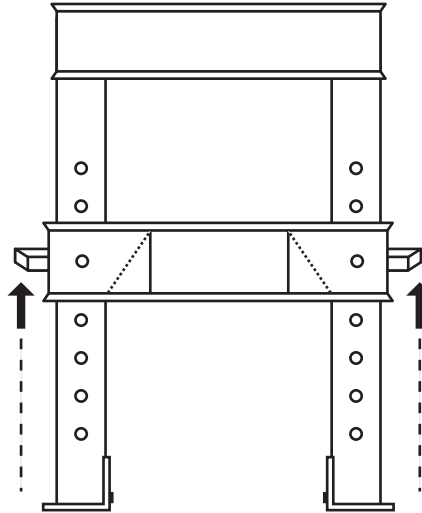

Slide bed above holes and *hold in place*

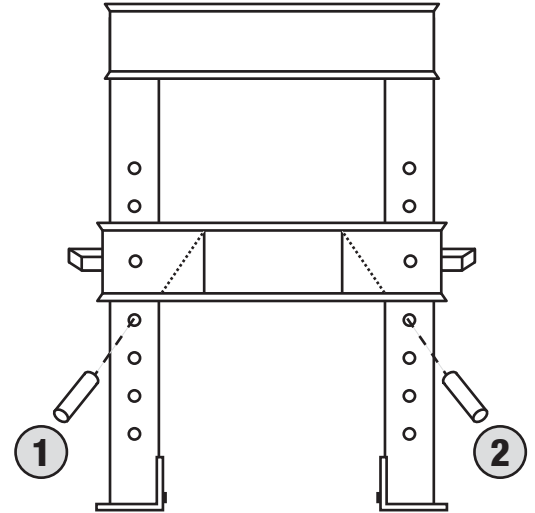

Secure pins underneath bed, one at a time

7

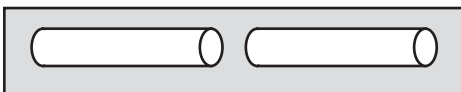

⚠ WARNING

ALL FOUR (4) pins must be COMPLETELY through BOTH SIDES of frame in order to operate press.

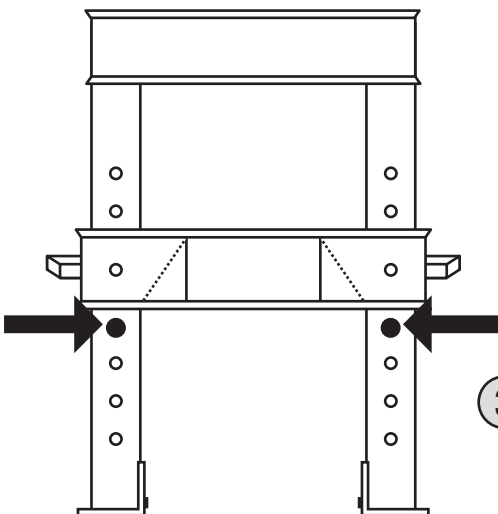

Let bed rest on inserted pins

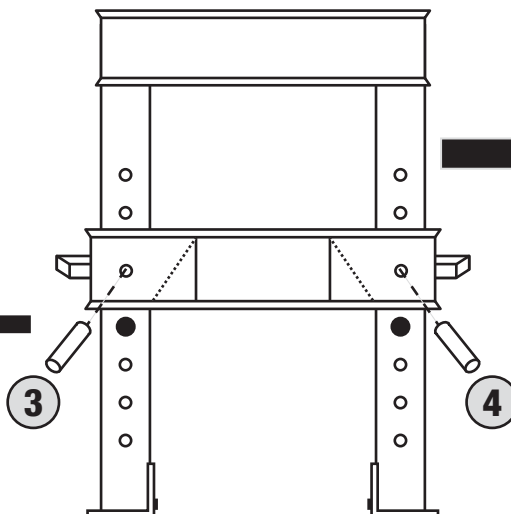

Place 3rd and 4th pin on each side

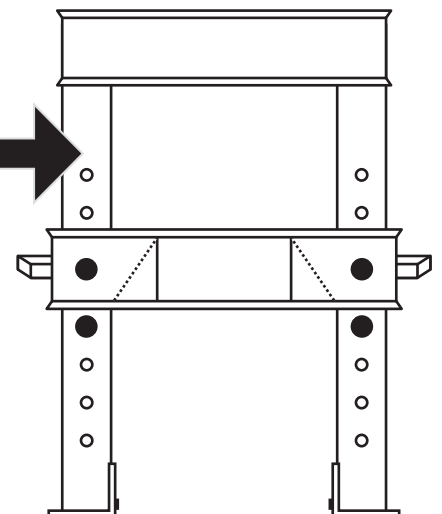

Secure pins completely through bed and frame.

PUMP AND RAM ASSEMBLY INSTRUCTIONS

8

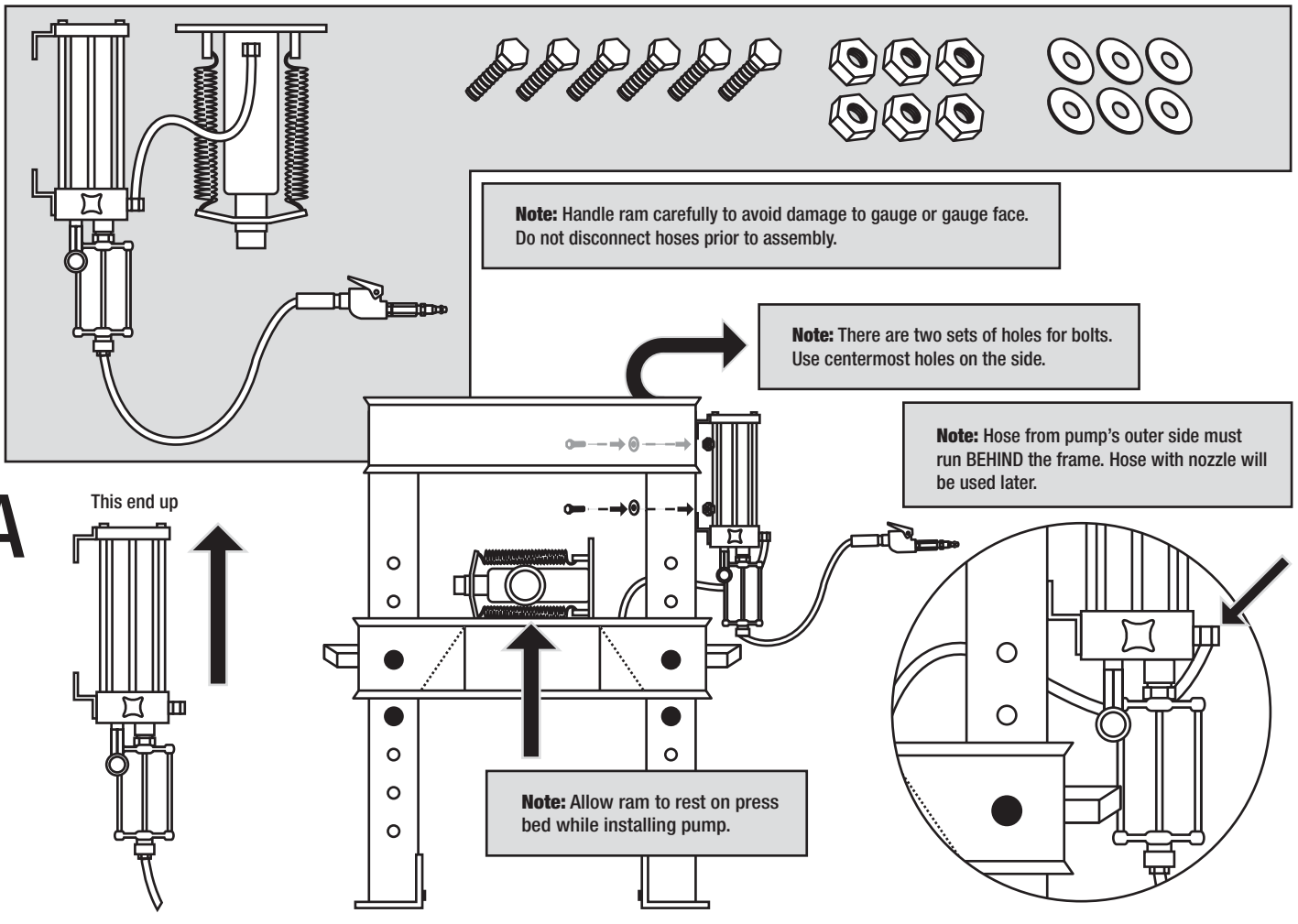

B

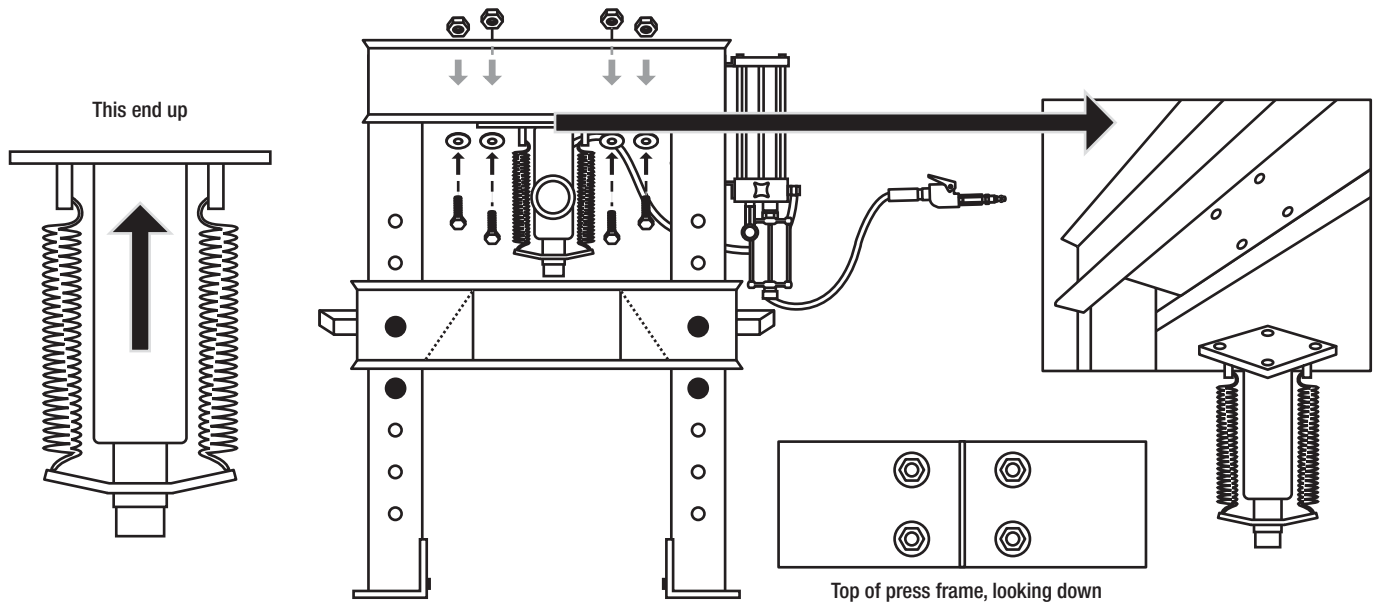

WARNING

DO NOT attempt to operate pump unless the BREATHER VALVE IS OPEN. Valve is closed prior to shipping to prevent the loss of hydraulic fluid.



PROCEDURE FOR BLEEDING AIR

9

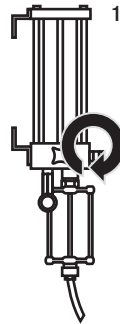
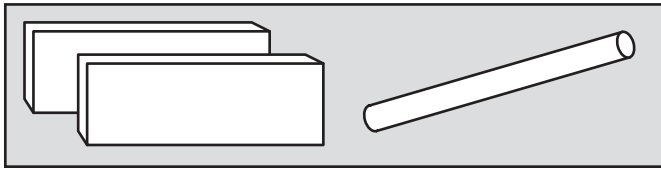

1. Turn valve handle on FRONT of pump CLOCKWISE until closed. DO NOT OVERTIGHTEN.

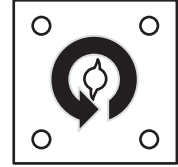

2. Turn petcock valve (breather) on TOP of pump COUNTERCLOCKWISE to open.

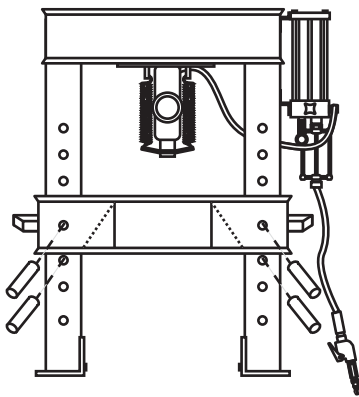

3. Move press bed into highest position and lock bed into place with all four pins.

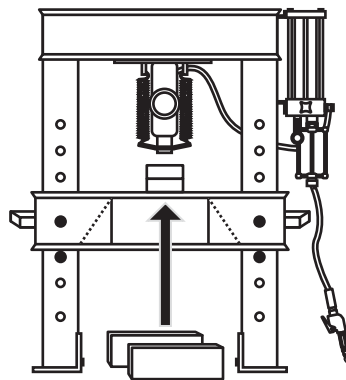

4. Place press plates DIRECTLY under ram, on press bed.

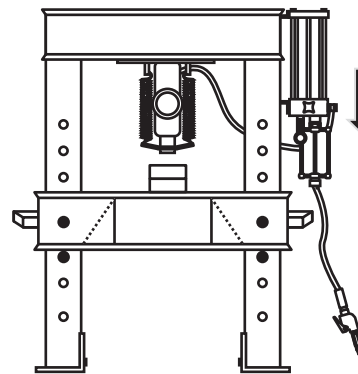

5. Put cradle in the DOWN position. Use an adapter on your air hose and allow air to flow through the opening in the petcock valve into the pump.

Note: Air motor must be operating at the same time.

CAUTION

Bed must be in UP position, or you will over extend ram.

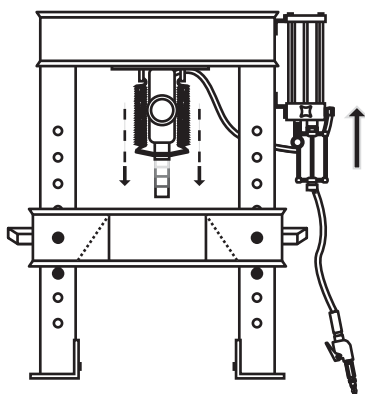

6. Air that has flowed into the pump causes the cradle to move up and the ram to move down. If this happens, proceed to step 7. If not, check all hoses and connections and repeat the procedure.

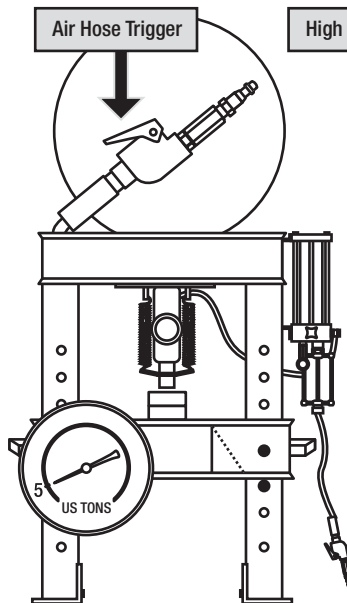

7. Squeeze trigger on air hose. Air will enter motor and extend the ram. Pump ram against press plates until gauge reads "5 Tons".

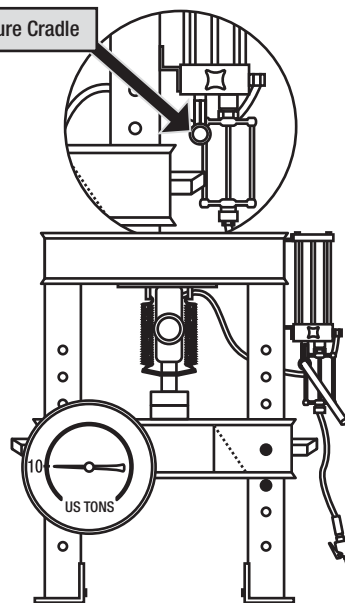

8. Insert pump handle into HIGH PRESSURE CRADLE for more precise control. Pump ram against press plates until gauge reads "10 Tons".

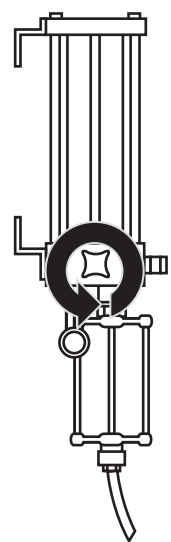

9. Turn valve handle on pump COUNTERCLOCKWISE a maximum of one (1) turn to open valve. Ram will retract as pressure is released.

WARNING

Do not allow the ram to extend more than 5.5".

PUMP INSTRUCTIONS

10

⚠ WARNING

This symbol alerts you to the possibility of serious injury or death if instructions are not followed.

Failure to heed these warnings may result in loss of load, damage to the press and/or failure resulting in property damage, personal or fatal injury. This operating manual contains important details concerning the safe operation of this tool. The user must read and understand these details before any use of the tool.

This manual must be retained for future reference.

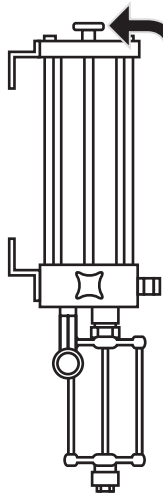

1. BEFORE OPERATING PUMP, open petcock valve (breather) located on TOP of pump assembly by turning COUNTERCLOCKWISE.

Top view of pump

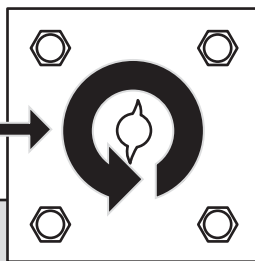

⚠ WARNING

DO NOT attempt to operate pump unless the BREATHER VALVE IS OPEN. Valve is closed prior to shipping to prevent the loss of hydraulic fluid.

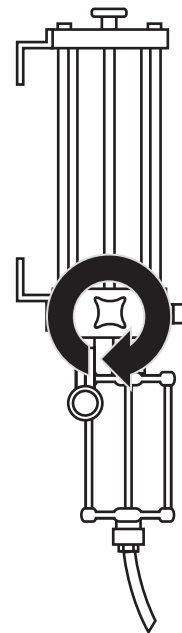

2. CLOSE the valve located on the FRONT of the pump assembly by turning CLOCKWISE.

⚠ CAUTION

HAND TIGHTEN VALVE ONLY. Excess pressure could damage the valve assembly.

Air Hose Trigger

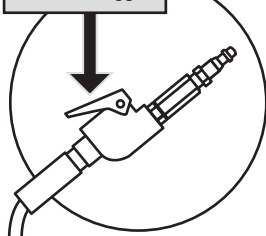

High Pressure Cradle

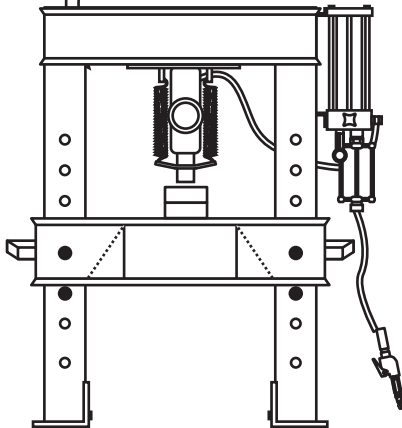
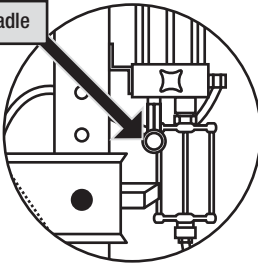

3. Squeeze air hose trigger until ram comes into contact with item to be pressed.

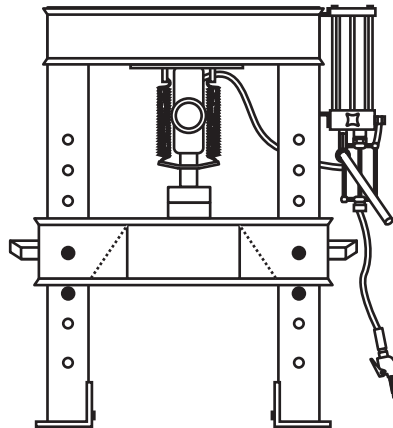

4. Once ram is in contact with the item to be pressed, insert pump handle into high pressure cradle. Using the high pressure pump moves the ram less with each stroke and requires less effort to apply pressure.

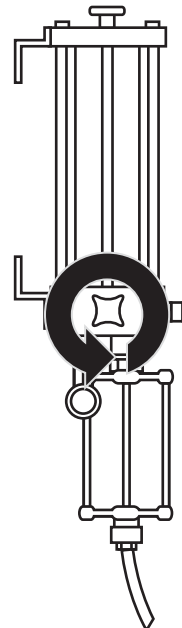

⚠ CAUTION

DO NOT TURN RELEASE VALVE MORE THAN ONE FULL TURN or equipment may be disabled.

5. To relieve pressure and retract ram, turn valve located on FRONT of pump assembly ONE FULL TURN COUNTERCLOCKWISE.

REPLACEMENT PARTS LIST

5240AO - 40 Ton Air Over Shop Press

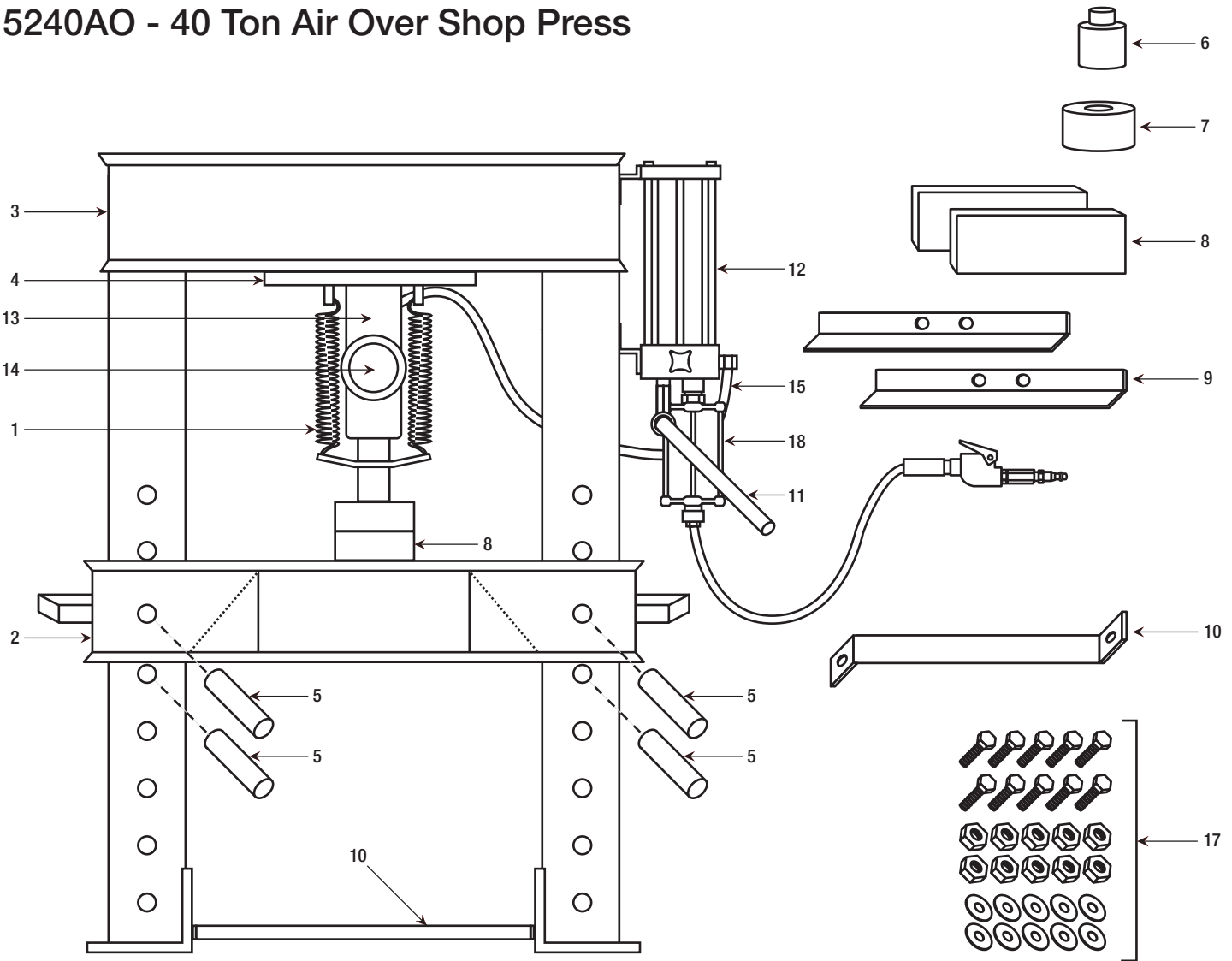

ITEM NO.	SUNEX PART NO.	DESCRIPTION	QTY.	ITEM NO.	SUNEX PART NO.	DESCRIPTION	QTY.
1	RS345009	Spring	2	11	RSCBP1209	Pump Handle	1
2		Press Bed	1	12	RS40AOPAM	Pump (with air motor)	1
3		Press Frame	1	13	RSCBP1202	Ram	1
4		Ram Frame	1	14	RSCBP1206	Gauge	1
5	RSCBP1225	Press Pin	2	15	RSCBP1204	Hose & Fitting	1
6	RS310012	Pushing Adapter	1	16	RSCBP1217	Seal Kit for Pump and Ram (not shown)	1
7	RSBS1	Bearing Shield	1	17	RS40MPPHK	Press Hardware Kit	1 set
8	RSCBP1205	Press Plate	2			1/2"-13 x 1-1/2" Hex Head Bolt	10
9	RSCBP1211	Press Feet	2			1/2" Nut	10
10	RSCBP1212	Z Bar	1			Washer	10
				18	RS40AOAM	Air Motor (shown with pump)	1

Only items identified by part number are available separately.

PUMP AND RAM EXPLODED PARTS DIAGRAM

See Replacement Parts List for parts available separately.

Parts with (*) are only available in Seal Kit, part number RSCBP1217.

Individual parts pictured are components of the Seal Kit, RSCBP1217.

RAM

ITEM NO.	DESCRIPTION	QTY.
1	Base Weldment	1
2	Plug	1
3	* Polypak Seal (Parker)	2
4	1/2-13 x 2 Hex HD C-S GR 2 Zinc	1
5	Piston	1
6	* O-Ring (Parker)	1
7	Rod	1
8	Retaining Ring Int. 3.5 NOM	1
9	Piston Guide	1
10	Retractor Plate	1
11	Spring	2
12	Fitting Gauge 1.75	1
13	Gauge	1
14	90° Elbow 1/4 NPTF to -6 JIC	1
15	Hose Hydraulic 41 1/2 LG 7/16-20 JICF	1

PUMP

ITEM NO.	DESCRIPTION	QTY.
1	Tank	1
2	Tie Rod	4
3	1" Piston Body	1
4	1/2" Piston Body	1
5	1" Piston	1
6	1/2" Piston	1
7	1/4" MNPT Pressure Plug	1
8	Pump Body	1
9	Pump Lid	1
10	Pump Bracket	2
11	Valve Assembly	1
12	Pivot Pin	2
13	* 5/16 Steel Ball	5
14	Brass Drain Cock	1
15	Cradle Assembly	2
16	Hydraulic Hose 41-1/2" L 7/16-20 JICF	1
17	7/16-14 Fin Hex Nut Zinc	4
19	* O-Ring	1
20	* O-Ring	1
21	* 3-1/2" Seal	2
22	* 3-5/16" Seal	1
23	* 3-3/16" Seal	1
24	SHCS 7/16 14 x 1/2"	4
25	SHCS 7/16 14 x 3/4"	4
26	* Light Spring	2
27	* Heavy Spring	2
28	7/16" Split Lock Washer	6
29	Pump Filter	1
30	Pump Fitting 1/4" MNPT 7/16" JICF	1
31	7/8" Grip	1
32	Handle for Pump	1
33	* O-Ring	1

