



PROFESSIONAL AIR TOOLS



! WARNING

Some dust created by power sanding, sawing, grinding, drilling, and other construction activities contains chemicals known to cause cancer, birth defects or other reproductive harm. Some examples of these chemicals are:

- lead from lead-based paints,
- crystalline silica from bricks and cement and other masonry products, and
- arsenic and chromium from chemically-treated lumber.

Your risk from these exposures varies, depending on how often you do this type of work. To reduce your exposure to these chemicals: work in a well ventilated area, and work with approved safety equipment, such as those dust masks that are specially designed to filter out microscopic particles.

! WARNING



ALWAYS READ INSTRUCTIONS BEFORE USING POWER TOOLS



ALWAYS WEAR SAFETY GOGGLES



WEAR HEARING PROTECTION



AVOID PROLONGED EXPOSURE TO VIBRATION

8" ANGLE

POLISHER

6-715

! WARNING

FAILURE TO OBSERVE THESE WARNINGS COULD RESULT IN INJURY.



This Instruction Manual Contains Important Safety Information.

READ THIS INSTRUCTION MANUAL CAREFULLY AND UNDERSTAND ALL INFORMATION BEFORE OPERATING THIS TOOL.



- Always operate, inspect and maintain this tool in accordance with American National Standards Institute Safety Code of Portable Air Tools (ANSI B186.1) and any other applicable safety codes and regulations.
- For safety, top performance and maximum durability of parts, operate this tool at 90 psig; 6.2 bar max air pressure with 3/8" diameter air supply hose.



- Always wear impact-resistant eye and face protection when operating or performing maintenance on this tool. Always wear hearing protection when using this tool.



- High sound levels can cause permanent hearing loss. Use hearing protection as recommended by your employer or OSHA regulation.
- Keep the tool in efficient operating condition.



- Operators and maintenance personnel must be physically able to handle the bulk, weight and power of this tool.

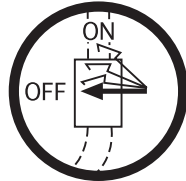

- Air under pressure can cause severe injury. Never direct air at yourself or others. Always turn off the air supply, drain hose of air pressure and detach tool from air supply before installing, removing or adjusting any accessory on this tool, or before performing any maintenance on this tool. Failure to do so could result in injury. Whip hoses can cause serious injury. Always check for damaged, frayed or loose hoses and fittings, and replace immediately. Do not use quick detach couplings at tool. See instructions for correct set-up.



- Air powered tools can vibrate in use. Vibration, repetitive motions or uncomfortable positions over extended periods of time may be harmful to your hands and arms.



Discontinue use of tool if discomfort, tingling feeling or pain occurs. Seek medical advice before resuming use.

- Place the tool on the work before starting the tool. Do not point or indulge in any horseplay with this tool.

- Slipping, tripping and/or falling while operating air tools can be a major cause of serious injury or death. Be aware of excess hose left on the walking or work surface.

- Keep body working stance balanced and firm. Do not overreach when operating the tool.

- Anticipate and be alert for sudden changes in motion during start up and operation of any power tool.

- Do not carry tool by the hose. Protect the hose from sharp objects and heat.

- Tool shaft may continue to rotate briefly after throttle is released. Avoid direct contact with accessories during and after use. Gloves will reduce the risk of cuts or burns.



- Keep away from rotating end of tool. Do not wear jewelry or loose clothing. Secure long hair. Scalping can occur if hair is not kept away from tool and accessories. Choking can occur if neckwear is not kept away from tool and accessories.



- Never mount a grinding wheel on a sander/polisher. A grinding wheel that bursts can cause very serious injury or death when not properly guarded. Inspect backing pads before each use. Do not use if cracked or damaged.



- Avoid direct contact with moving sanding/polishing pad to prevent pinching or cutting of hands or other body parts.

- Do not lubricate tools with flammable or volatile liquids such as kerosene, diesel or jet fuel.

- Do not force tool beyond its rated capacity.

- Do not remove any labels. Replace any damaged labels.

- Use accessories recommended by NAPA Professional Air Tools.

AIR SUPPLY

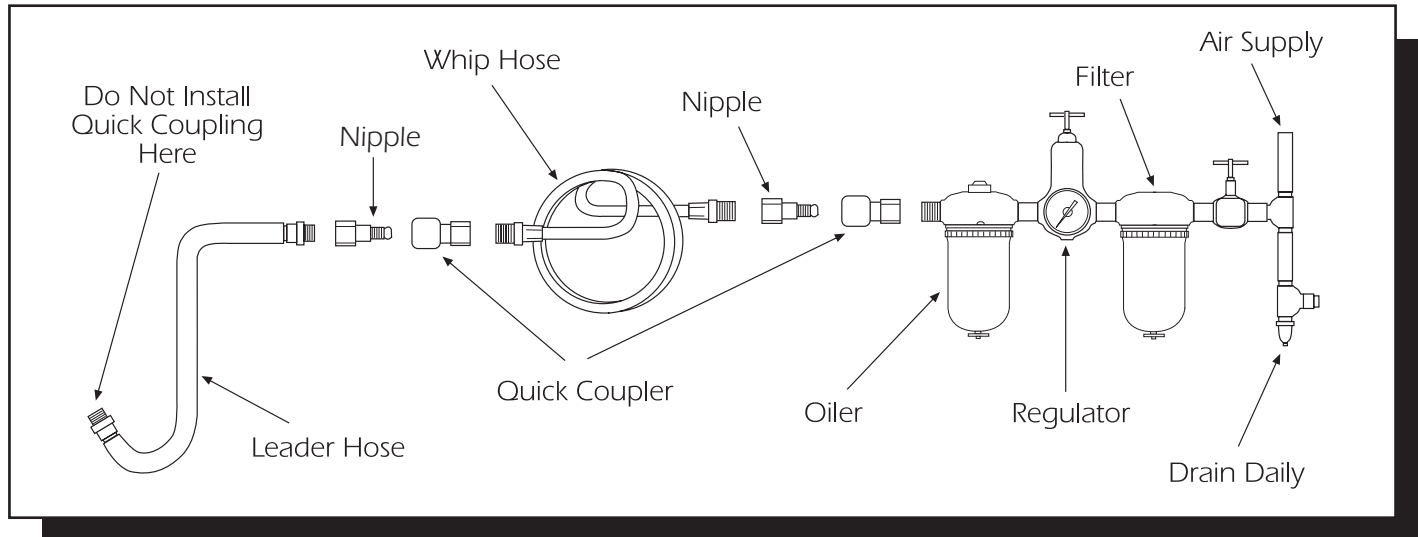

Tools of this class operate on a wide range of air pressures. It is recommended that air pressure of these tools measures 90 PSI at the tool while running free. Low pressure (under 90 psig; 6.2 bar) reduces the speed of all air tools. Low air pressure not only wastes time, but also costs money. Higher pressure (over 90 psig; 6.2 bar) raises performance beyond the

rated capacity of the tool, which will shorten tool life because of faster wear and could cause injury.

Always use clean, dry air. Dust, corrosive fumes and/or water in the air line will cause damage to the tool. Drain the air tank daily. Clean the air inlet filter screen on at least a weekly schedule. The recommended hookup procedure can be viewed in the above figure.

The air inlet used for connecting air supply, has standard 1/4" NPT American Thread. Line pressure should be increased to compensate for unusually long air hoses (over 25 feet). Minimum hose diameter should be 3/8" I.D. and fittings should have the same inside dimensions and be tightly secured.

LUBRICATION

Lubricate the air motor daily with NAPA air tool oil. If no air line oiler is used, run 1/2 ounce of oil through the tool. The oil can be

squirted into the tool air inlet or into the hose at the nearest connection to the air supply, then run the tool. Overfilling will cause a

reduction in the power of the tool.

OPERATION

Before operating this polisher, it is important to ensure that the backing pad is secure. To do this, hold the stop spanner (#49) on the gear shaft and turn the pad clockwise until tight.

NOTE: Make sure dead handle is installed on appropriate side of polisher for positive grip while operating tool.

Let the polisher do the work. The normal weight of the machine is sufficient for efficient polishing. Do not put excessive pressure on the machine. This will only slow down the speed of the pad, reduce efficiency and put an additional burden on the motor. Start the polisher off work, set it down on the work evenly and move it slowly

back and forth in wide, overlapping areas. When finished polishing, lift it off the work before stopping the motor.

The speed of the polisher can be regulated using the Air Regulator slot on the top of the tool. When the regulator shaft is rotated a full quarter turn in either direction, the tool speed will go from maximum to zero. Reposition the regulator shaft within the quarter turn until the desired speed is obtained.

SPECIFICATIONS

Overall Length	16"
Net Wt.	6.5 lbs.
Avg. Air Cons.	6 CFM
Air Inlet	1/4" NPT
Hose Size	3/8" ID
Free Speed	2500 RPM
Sound Level	90 dBA



WARRANTY POLICY: NAPA PROFESSIONAL AIR TOOLS are warranted against defects in material and workmanship for a period of one (1) year from the date of the original purchase. We will repair or replace at our option any defective part or unit which proves to be defective in material or workmanship during this one year period. All NAPA PROFESSIONAL AIR TOOLS must be repaired only by authorized NAPA PROFESSIONAL AIR TOOL Service Centers. This warranty does not cover damage to tools rising from alteration, abuse, misuse and does not cover any repairs made by anyone other than an authorized NAPA PROFESSIONAL AIR TOOL Warranty Center. Tools sent to a Warranty Center in a disassembled condition will not be covered as a warranty repair.

Return tools to Service Centers transportation prepaid. Be certain to include your name, address and phone number along with proof of purchase information, with each tool.

TROUBLESHOOTING

IMPACT WRENCHES

TOOL RUNS SLOWLY OR NOT AT ALL AND/OR AIR FLOWS ONLY SLIGHTLY FROM EXHAUST — This is probably caused by: air flow blocked by dirt build-up; motor parts jammed with dirt; power regulator has vibrated to closed position.

YOU SHOULD: Check air inlet strainer for blockage. Pour a generous amount of air tool oil into air inlet. Operate tool in short bursts, in both forward and reverse motion. Repeat if necessary. If tool performance is not improved, it should be serviced at an authorized service center.

TOOL WILL NOT RUN, EXHAUST AIR FLOWS FREELY. This is probably caused by one or more motor vanes stuck due to accumulation of sludge or varnish ; motor rusted.

YOU SHOULD: Pour a generous amount of air tool oil into air inlet. Operate tool in short bursts, in both forward and reverse motion. Lightly tap motor housing with plastic mallet. Detach air supply. Try to free motor by turning drive shank manually, if possible. If tool remains jammed, it should be serviced at authorized service center.

SOCKETS WILL NOT STAY ON. This is probably caused by: worn socket retainer ring or soft back-up ring.

YOU SHOULD: Wear safety goggles. Detach air supply. Using external retaining ring pliers, remove old retaining ring. Holding square drive with appropriate open-end wrench, use small screwdriver to pry old retainer ring out of groove. Always pry off ring away from your body - it can be propelled outward at high velocity. Replace back-up O-ring and retainer ring with correct new parts. (See breakdown). Place retaining ring on table, press tool anvil into ring in a rocking motion. Snap into groove by hand.

PREMATURE ANVIL WEAR. This is probably caused by: use of chrome sockets or worn sockets.

YOU SHOULD: Stop using chrome sockets. Chrome sockets have a hard surface and a soft core. Drive hole becomes rounded - but will still be very hard. Besides the danger of splitting, wrench anvils will wear out prematurely when used with chrome sockets.

TOOL SLOWLY LOSES POWER BUT STILL RUNS AT FULL FREE SPEED. This is probably caused by: worn clutch parts, due to inadequate lubrication; engaging cam of clutch worn or sticking due to inadequate lubrication.

YOU SHOULD: FOR OIL LUBED WRENCHES

- check for presence of clutch oil (where oil is specified for clutch) and remove oil fill plug; tilt to drain all oil from clutch case; refill with 30 weight SAE oil or that recommended by manufacturer, in the specified amount. Also check for excess clutch oil. Clutch cases need only be filled 50%. Overfilling can cause drag on high speed clutch parts. A typical 1/2" oil-lubed wrench only requires 1/2 ounce of clutch oil. **FOR GREASE LUBED WRENCHES** - Check for excess grease by rotating drive shank by hand. It should turn freely. Excess is usually expelled automatically.

TOOL WILL NOT SHUT OFF. This is probably caused by: throttle valve O-ring broken or out of position or throttle valve stem bent or jammed with dirt particles.

YOU SHOULD: Remove assembly and install new O-ring. Lubricate with air tool oil and operate trigger briskly. If operation cannot be restored, tool should be serviced at authorized service center.

AIR RATCHETS

MOTOR RUNS. SPINDLE DOESN'T TURN, OR TURNS ERRATICALLY — This is probably caused by: worn teeth on ratchet or pawl; weak or broken pawl pressure spring; weak drag springs fail to hold spindle while pawl advance for another bite.

YOU SHOULD: have replacement parts installed by authorized service center.

TOOL DOESN'T RUN, RATCHET HEAD INDEXES CRISPLY BY HAND— This is probably caused by: dirt or sludge build-up in motor parts.

YOU SHOULD: Pour a generous amount of air tool oil into air inlet. Operate throttle in short bursts. With socket engaged on bolt, alternately tighten and loosen bolt by hand. If tool remains jammed, it should be serviced at authorized service center.

AIR DRILLS

TOOL WILL NOT RUN, RUNS SLOWLY, AIR FLOWS SLIGHTLY FROM EXHAUST, SPINDLE TURNS FREELY — This is probably caused by: air flow blocked by dirt build-up; motor parts jammed with dirt.

YOU SHOULD: Check air inlet for blockage. Pour a generous amount of air tool oil into air inlet. Operate trigger in short bursts. Detach air supply; turn empty and closed drill chuck by hand. Reconnect air supply. If tool performance is not improved, it should be serviced at an authorized service center.

TOOL WILL NOT RUN, AIR FLOWS FREELY FROM EXHAUST, SPINDLE TURNS FREELY — This is probably caused by: Build up of dirt or varnish on rotor vanes.

YOU SHOULD: Pour a generous amount of air tool oil into air inlet. Operate trigger in short bursts. Detach air supply; turn empty and closed drill chuck by hand. Reconnect air supply. If tool performance is not improved, it should be serviced at an authorized service center.

TOOL LOCKED UP, SPINDLE WILL NOT TURN — This is probably caused by: a broken rotor vane; gears broken or jammed by foreign object.

YOU SHOULD: Send the tool to an authorized service center.

TOOL WILL NOT SHUT OFF — This is probably caused by: throttle valve O-ring blown off seat.

YOU SHOULD: See breakdown for part number and replace O-ring or send the tool to an authorized service center.

AIR HAMMERS

TOOL WILL NOT RUN — This is probably caused by: cycling valve or throttle valve clogged with dirt or sludge.

YOU SHOULD: Pour a generous amount of air tool oil into air inlet; check for dirt. Operate trigger in short burst (chisel in place and against solid surface). If not free, detach air supply. Tap nose or barrel lightly with plastic mallet, reconnect air supply, and repeat above steps. If still not free, detach air supply, insert a 6" piece of 1/8" diameter rod in nozzle and lightly tap to loosen piston in rear direction. Reconnect air supply and repeat above steps.

CHISEL STUCK IN NOZZLE— This is probably caused by: the end of the shank being deformed.

YOU SHOULD: Send the tool to an authorized service center.

NOTE

Disassembly of this tool by other than an authorized service center will void the warranty on this tool.

PARTS BREAKDOWN

6-715

8" ANGLE POLISHER

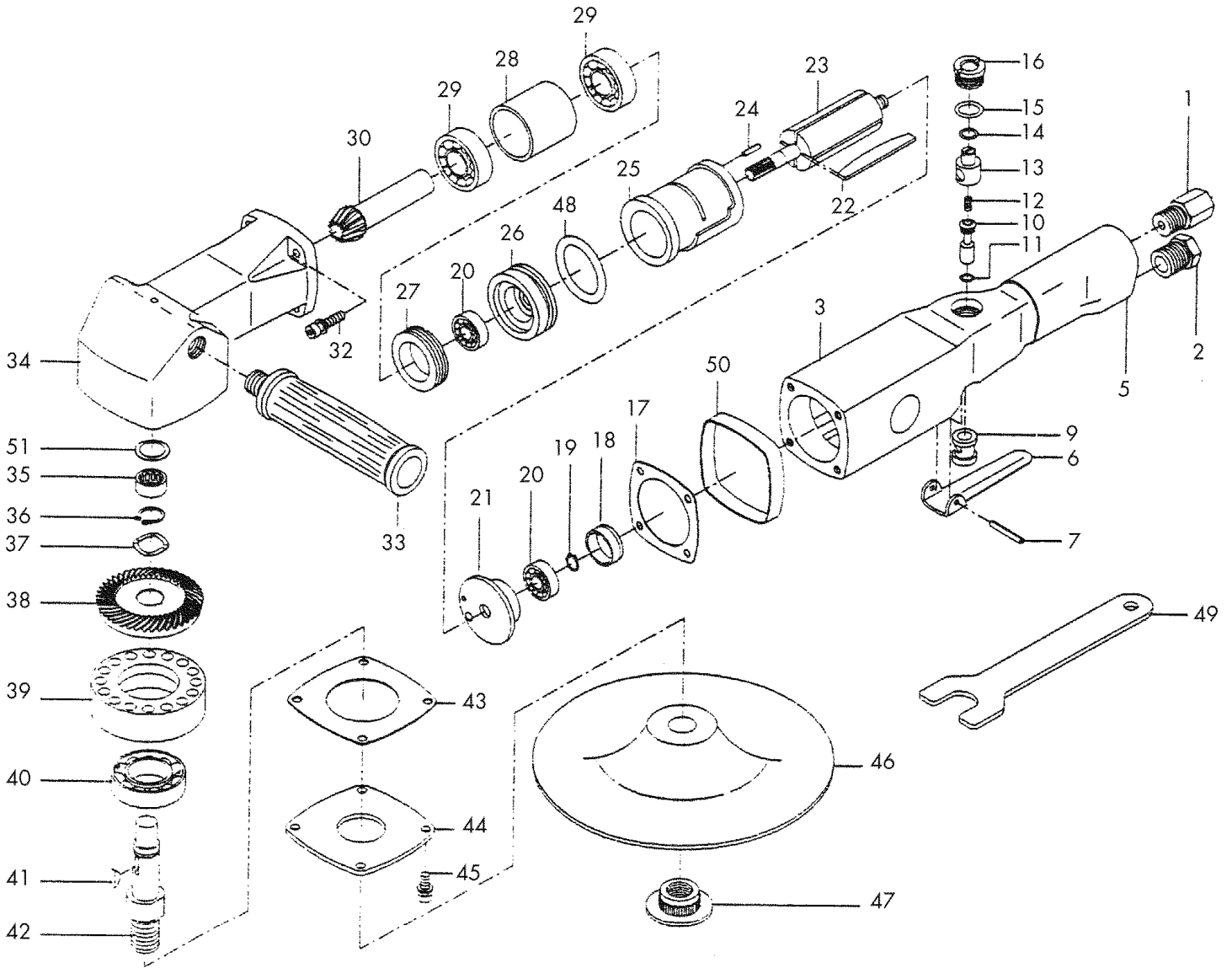

PARTS LIST

6-715

8" ANGLE POLISHER

Item#	Part #	Description	Qty.
1	RS71601	Air Inlet	1
2	RS71602	Exhaust Bushing	1
3	RS71603	Motor Housing	1
5	RS71605	Handle Cover	1
6	RS71606	Lever	1
7	RS71607	Throttle Lever Pin	1
9	RS71609	Throttle Valve Bushing	1
10	RS71610	Valve Stem	1
11	RS71611	O-Ring	1
12	RS71612	Spring	1
13	RS71613	Air Regulator	1
14	RS71614	O-Ring	1
15	RS71615	O-Ring	1
16	RS71616	Valve Screw	1
17	RS71617	Gasket	1
18	RS71618	Bearing Cap	1
19	RS71619	Retainer Ring	1
20	RS21417	Ball Bearing	2
21	RS71621	Rear End Plate	1
22	RS71622	Rotor Blade	4
23	RS71623	Rotor	1
24	RS71624	Dowel Pin	1
25	RS71625	Cylinder	1
26	RS71626	Front End Plate	1
27	RS71627	Clamp Nut	1
28	RS71628	Spacer	1
29	RS21109	Ball Bearing	2
30	RS71530	Bevel Gear Shaft	1
32	RS71632	Allen Cap Screw	4
33	RS71633	Dead handle	1
34	RS71634	Housing-Angle	1
35	RS71635	Needle Bearing	1
36	RS71636	Retainer Ring	1
37	RS71637	Wave Washer	1
38	RS71538	Bevel Gear	1
39	RS71639	Bearing Bushing	1
40	RS71640	Ball Bearing	1
41	RS71641	Woodruff Key	1
42	RS71642	Gear Shaft	1
43	RS71643	Gasket	1
44	RS71644	Angle Housing Cover	1
45	RS71645	Screw with Lock Washer	4
46	RS71646	Sander Pad	1
47	RS71647	Retaining Nut	1
48	RS71648	O-Ring	1
49	RS71649	Stop Spanner	1
50	RS71650	Rubber	1
51	RS71651	Bearing Plate	1