

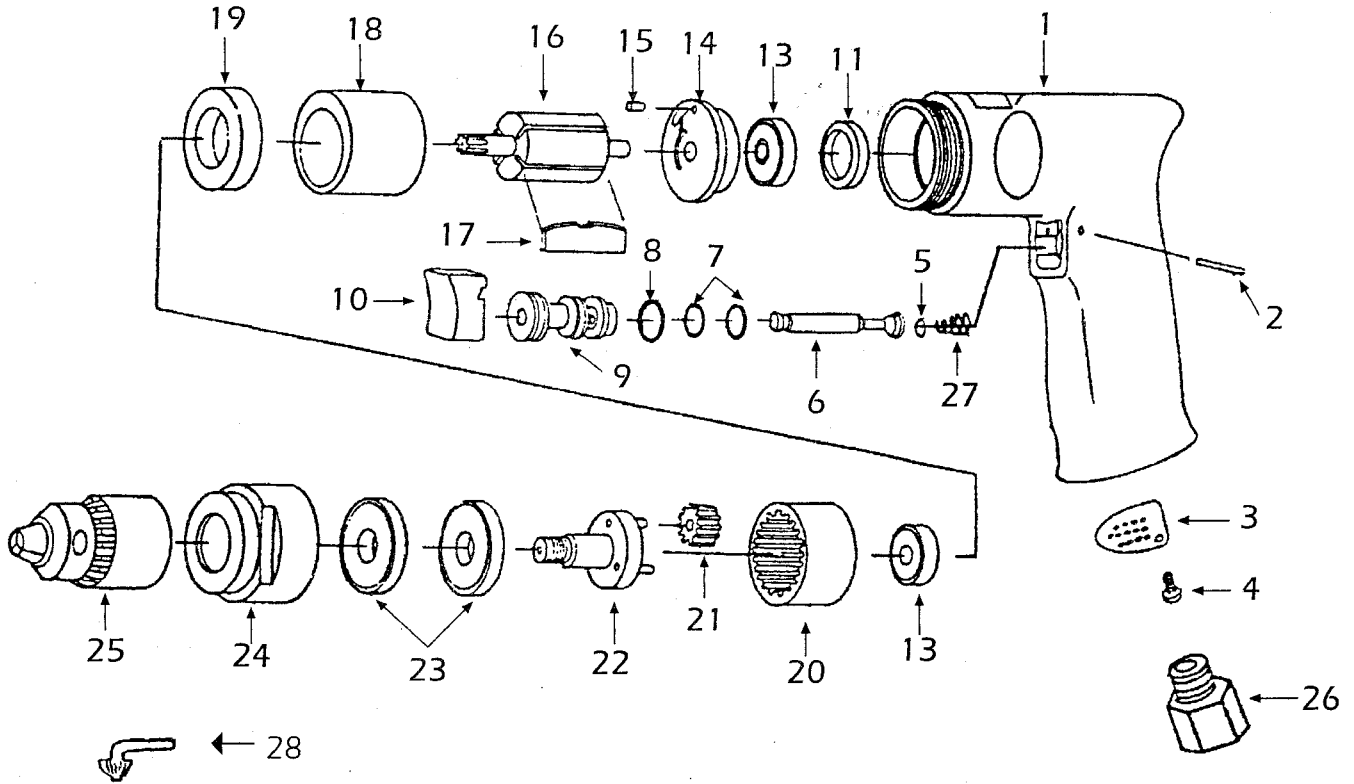

SX-228A

3/8" 2600 RPM Drill



REF. NO.	PART NO.	DESCRIPTION	QTY.
1	22801	Motor Housing	1
2	22802	Pin	1
3	22803	Exhaust Deflector	1
4	22804	Screw	1
5	22805	O-Ring	1
6	22806	Valve Stem	1
7	22807	O-Ring	2
8	22808	O-Ring	1
9	22809	Valve Bushing	1
10	22810	Trigger	1
11	22811	Bearing Cap	1
13	21114	Ball Bearing	2
14	22814	Rear End Plate	1

REF. NO.	PART NO.	DESCRIPTION	QTY.
15	22815	Pin	1
16	22816	Rotor	1
17	22817	Rotor Blade	4
18	22818	Cylinder	1
19	22819	Front End Plate	1
20	22820	Ring Gear	1
21	22821	Idler Gear	3
22	22822	Idler Gear Plate	1
23	22823	Ball Bearing	2
24	22824	Lock Nut	1
25	87106	Chuck & Key	1
26	22826	Bushing	1
27	22827	Spring	1
28	87106KK	Chuck Key	1