

SX-294-6

Heavy Duty Dual Action Sander

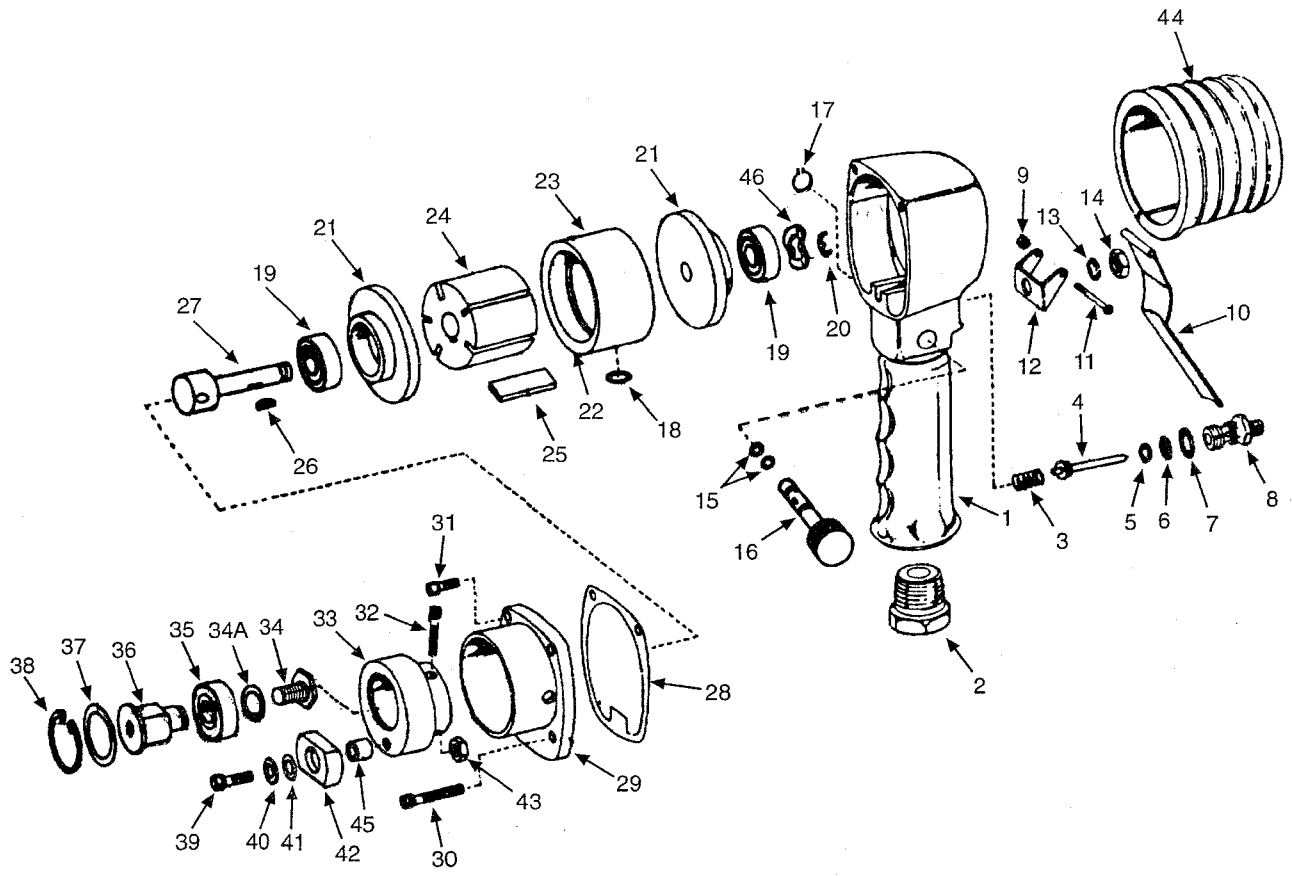

SUNEX™
T O O L S



Index #	Part #	Description	Qty.	Index #	Part #	Description	Qty.
1	30301	Motor Housing (With Grip Rubber)	1	25	30325	Rotor Blade	4
2	30302	Hose Adapter	1	26	30326	Key	1
3	30303	Throttle Valve Spring	1	27	30327	Rotor Shaft	1
4	30304A	Valve Stem	1	28	30328	Gasket	1
5	30305	"O" Ring	1	29	30329	Drive Housing	1
6	30306	"O" Ring	1	30	30330	Cap Screw (L)	2
7	30307	"O" Ring	1	31	30331	Cap Screw (S)	2
8	30308	Valve Body	1	32	30332	Socket Screw	1
9	30309	Hex Nut	1	33	30333	Orbital Hub	1
10	30310	Throttle Lever	1	34	30334	Front Screw	1
11	30311	Hinge Screw	1	34A	30334A	Wave Washer	1
12	30312	Bracket	1	35	21118	Ball Bearing	1
13	30313	Lock Washer	1	36	30336	Drive Spindle	1
14	30314	Hex Nut	1	37	30337	Spring Washer	1
15	30315	"O" Ring	2	38	30338	Retaining Ring	2
16	30316	Valve-Speed Regulator	1	39	30339	Screw	1
17	30317	Retaining Ring	1	40	30340	Flat Washer	1
18	30318	"O" Ring	1	41	30341	Spring Washer	1
19	29120	Ball Bearing	2	42	30342	Spindle Lock	2
20	30320	Retaining Ring	1	43	30343	Hex Nut	1
21	30321	End Plate	2	44	30344	Housing Cover	2
22	30322	Locating Pin	1	45	30345	Spacer	1
23	30323	Cylinder	1	46	30346	Wave Washer	1
24	30324	Rotor	1	50	87511	5" Sanding Pad (optional)	1
				60	87513	6" Sanding Pad (standard)	1